

KTS screw pumps

KNOLL
.It works

Issue 09-2022

**AVAILABLE
EX STOCK**



Contents

KNOLL .It works	4
Benefits, properties, design	8
Type key, equipment, testing	10
Recommended filter quality, KTS selection	11
2900 rpm 50 Hz – output table 1 mm ² /s.....	12
2900 rpm 50 Hz – output table 20 mm ² /s.....	13
1450 rpm 50 Hz – output table 1 mm ² /s.....	14
1450 rpm 50 Hz – output table 20 mm ² /s.....	15
3500 rpm 60 Hz – output table 1 mm ² /s.....	16
3500 rpm 60 Hz – output table 20 mm ² /s.....	17
1750 rpm 60 Hz – output table 1 mm ² /s.....	18
1750 rpm 60 Hz – output table 20 mm ² /s.....	19
Speed control with PQ-Tronic.....	20
Pressure control comparison	22
KNOLL E-PASS.....	23
KNOLL E-PASS measurement results	24
Process monitoring with PQ-Tronic	26
PQ-Tronic application examples	27
Screw pump.....	28
List of individual parts	29
Pumps with submersion design	30
Pumps with legs.....	32
Frequency inverter (FI)	34
Standard multi-range motors.....	35
Pressure relief valves	36
Characteristic curves for controlled pressure relief valves	38

KNOLL .It works

KNOLL is the leading provider of conveyor systems, filtration systems and pumps for metalworking. These systems transport and separate chips and cooling lubricants. The comprehensive product range offers systems for decentralised or centralised applications.

Its Automation division deals with solutions for demanding assembly and logistics tasks. These include stationary transport systems with chain and roller conveyors. The integration of handling units (robots, cobots) and transport robots (AGV) enables flexible systems to be created from a single source.





The KTS screw pump has been a successful product for more than 30 years. It conveys cooling lubricants (oil, emulsion, aqueous solutions) for high-pressure applications on machine tools. A typical example is cooling, lubrication and chip transportation for tools with an internal cooling lubricant feed for drilling and milling. The KTS features innovative technology, excellent durability and high resistance to wear. Through the combination of cutting-edge manufacturing technologies, continuous development and a sophisticated logistics and service network, we have established a firm presence in this industry sector.



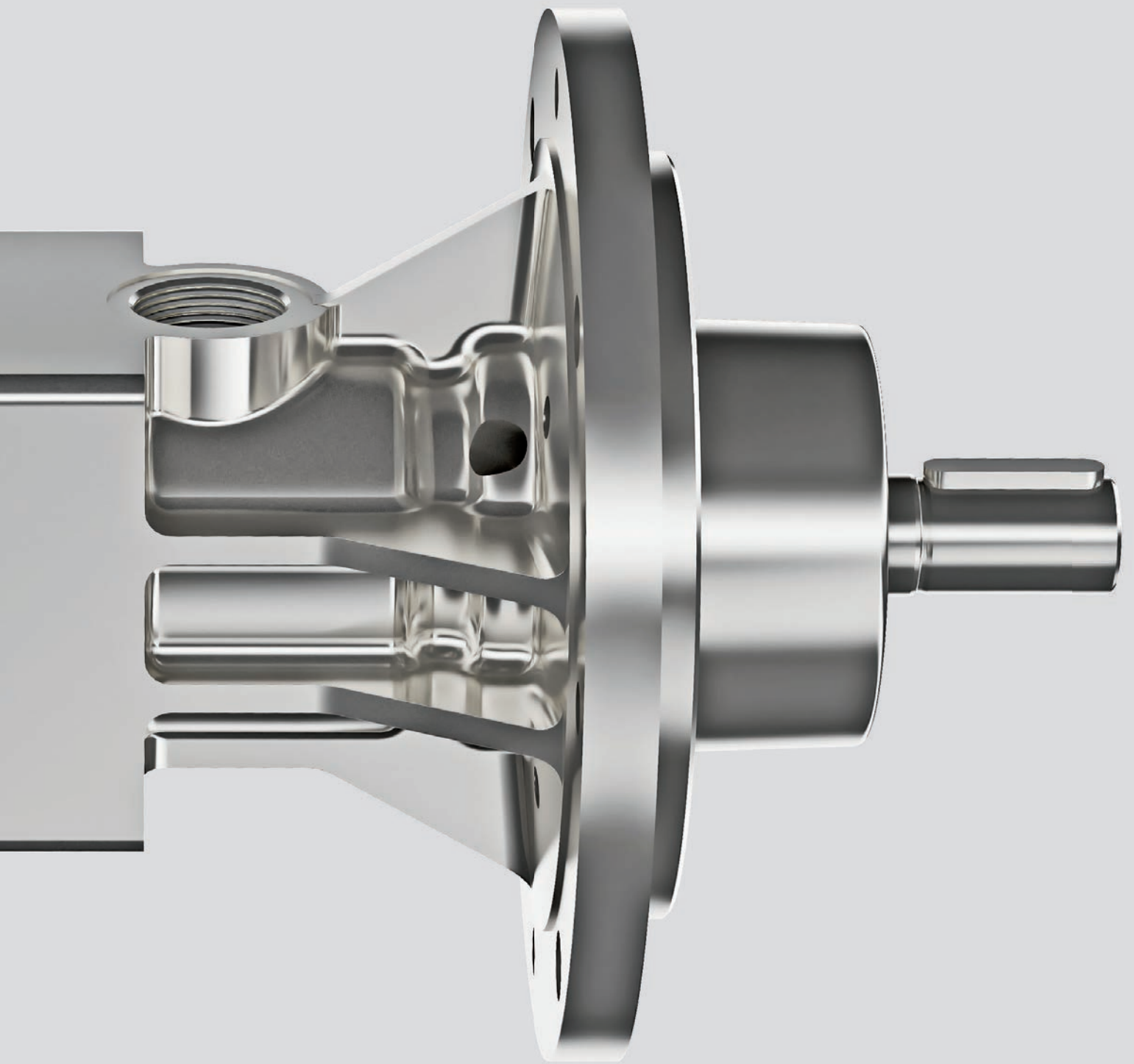

Properties

- Long service life thanks to high resistance to wear
- Low pulsation
- Extremely temperature-resistant
- Minimal noise generation
- Gentle fluid delivery

Specification

Delivery rate:	1 – 900 l/min
Pressure increase:	1 – 200 bar
Supply pressure:	Max. 20 bar
Temperature:	Max. 130 °C
Air content:	3 – 5 vol.%
Kinematic viscosity:	1 – 2500 mm ² /s

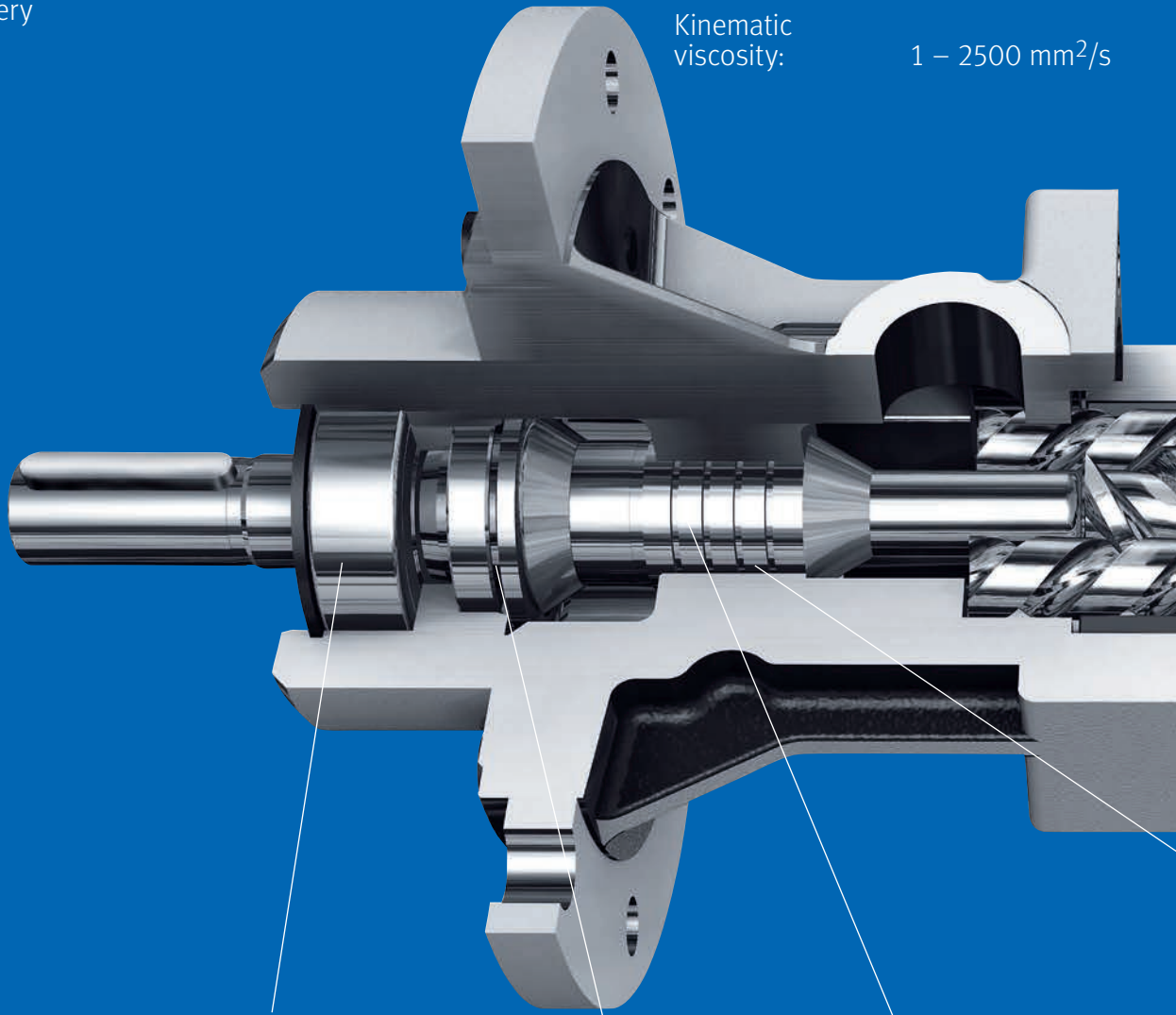

Design features

External main bearing
→ Long service life

Optional axial face
seal for dry installation

Labyrinth for effective
pressure reduction
→ high level of
effectiveness



Layout

Type KTS screw pumps by KNOLL are self-priming positive displacement pumps suitable for lubricating and non-abrasive materials. Each pump primarily consists of three components:

1. Suction casing, 2. Running casing with drive spindle and two running spindles, 3. Pressure casing with throttling point, sealed shaft passage and external main bearing. The running casing consists of two ceramic shells embedded in steel.

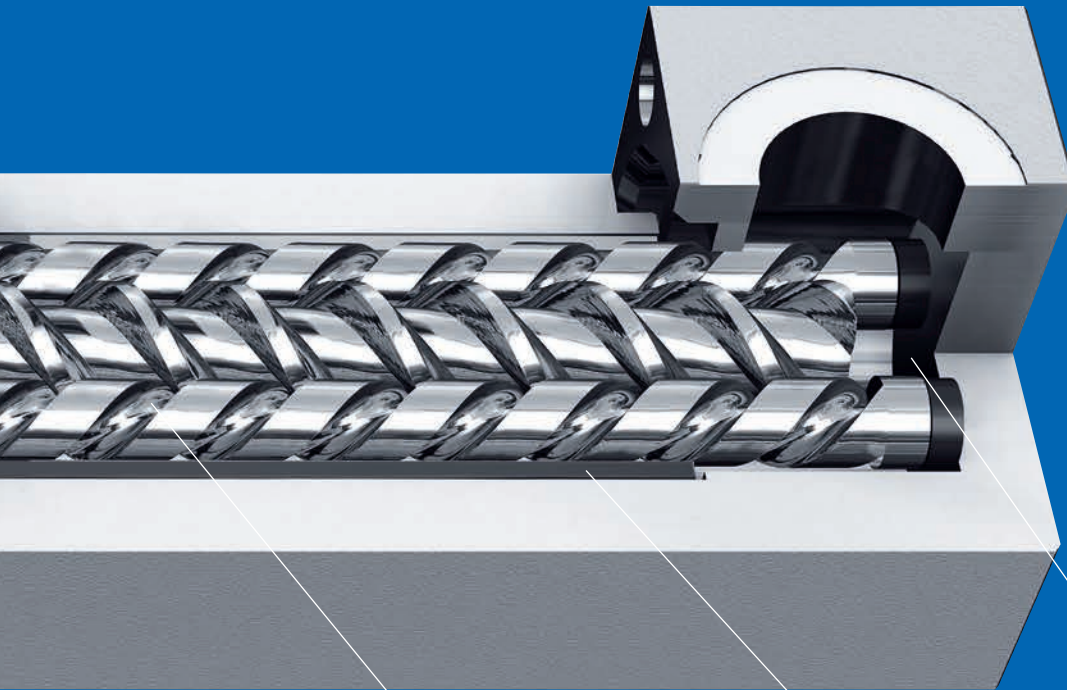

Optional ceramic piston bushing
-> Minimised wear at the throttle gap

Screw spindle made of tool steel, specially hardened and precision-manufactured
-> Long service life and high level of effectiveness

Running casing precision manufactured out of ceramics
-> Almost wear-free

Wear-resistant axial thrust compensation



Type key

KTS 25-50-T-A-G-KB-H-B

Configuration

Overall size

Spindle pitch

T design

Axial thrust compensation

G/G4 axial face seal

G = Supply pressure \leq 8 bar

G4 = Supply pressure 8 – 20 bar

Ceramic sleeve

High pressure $>$ 150 bar

Special coating

Equipment

Equipment	Type	KTS 20	KTS 25	KTS 32	KTS 40	KTS 50	KTS 60
Optional axial face seal	T (-G)	●	●	●	●	●	–
- Ceramic sleeve in the throttle point - Optional axial face seal	T (-G)-KB	●	●	●	●	●	–
- Special spindle coating - Ceramic sleeve in the throttle point - Axial face seal	T-G-KB-B	–	○	○	○	○	–
- Ceramic sleeve in the throttle point - Axial face seal - Axial thrust compensation	T-A-G-KB	○	○	–	–	–	●
- Special spindle coating - Wear-resistant sleeve in the throttle point - Axial face seal - Axial thrust compensation	T-A-G-KB-B	–	○*	○	○	○	–
Axial face seal for increased supply pressure	T-G4	○	○	○	○	○	–

● Preferred series ○ Option – not available for delivery

* Design only possible in T-A-G-KB-H-B

Design

All pumps are available in a submersion design for vertical installation (typically in containers) and in a design with legs for horizontal or vertical dry installation.

KTS pumps can also be fitted with PQ-Tronic speed regulation as an option.

Check

Precision based on checking rules

Q $>$ 100 l/min VDMA 24284, Class II, Group II

Q \leq 100 l/min KNOLL specification

Recommended filter quality

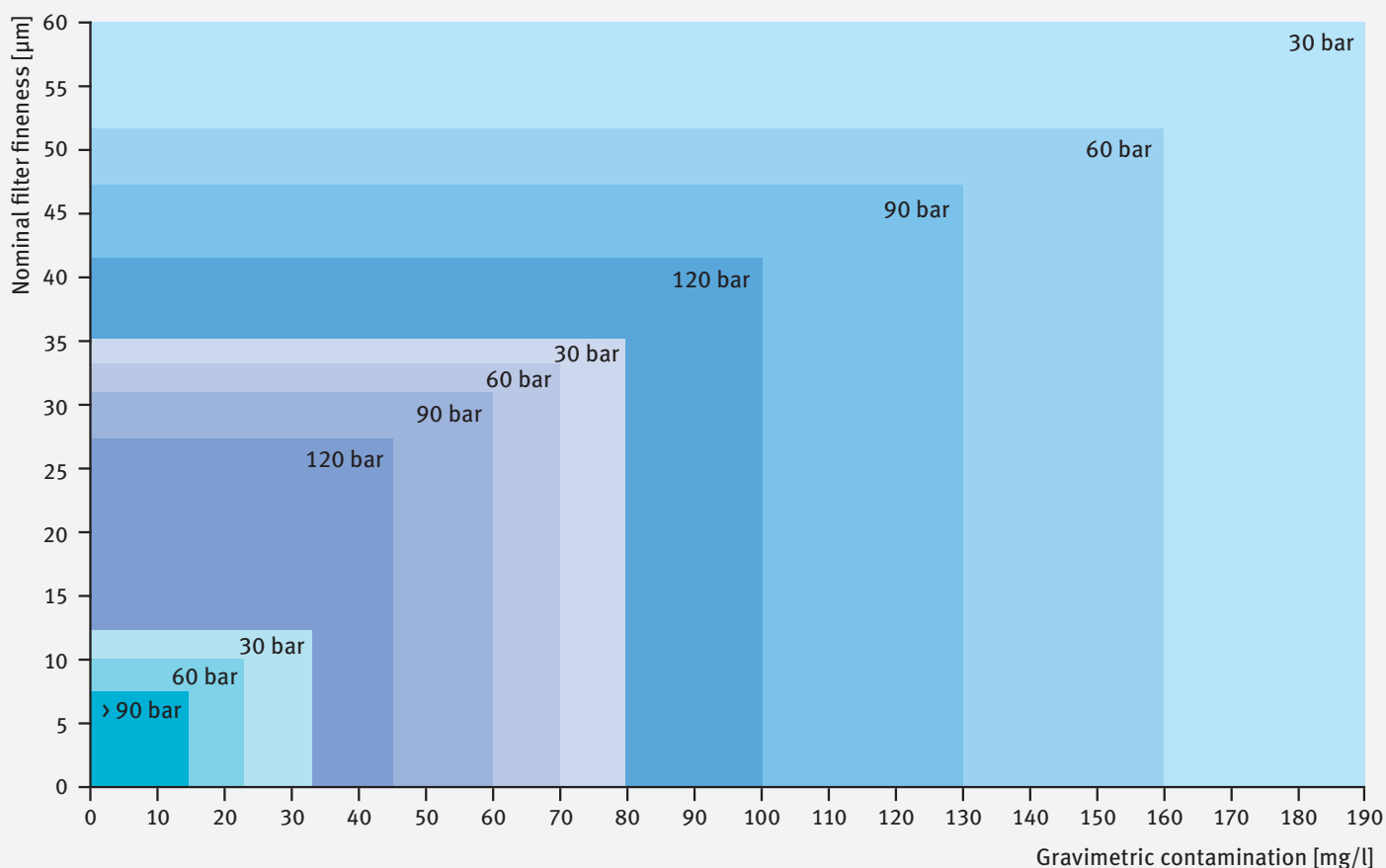

The specifications relate to the determination of the gravimetric contamination with a 5 µm cellulose membrane in 100 ml sample quantity.

Very hard particles*

1000 – 10,000 HV

e.g. corundum, ceramics, SiC, glass, carbides. Corundum available on request

Hard particles

500 – 1000 HV

e.g. hardened steels, cast materials with additives, AL with high Si content, abrasives: CBN/diamond

Soft particles < 500 HV

e.g. non-hardened steels, grey cast iron, non-ferrous metals

* Option B with coated spindles is recommended

KTS selection

Maximum pressures [bar]**

	Grinding		Grinding		Turning, milling, drilling		Turning, milling, drilling	
	Emulsion	Oil	Emulsion	Oil	Emulsion	Oil	Emulsion	Oil
T(-G/G4)	–	–	30	60	60	80	80	100
T(-G)-KB	–	–	60	90	80	100	100	120
T-G-KB-B	60	90	90	90	80	100	100	120
T-A-G-KB(-B)	60	90	90	120	120	120	150	150

** Pressures above 150 bar available on request

2900 rpm
50 Hz
1 mm²/s

Motor: 2-pole
Speed: 2900 rpm
Frequency: 50 Hz
Flow rate: Q [l/min]
Power demand: P [kW]
Viscosity: 1 mm²/s, e.g. emulsion

		Higher pressures available on request.														
Pressure [bar]:		10	20	30	40	50	60	70	80	90	100	110	120	130	140	150
Series	KTS 20-30 Q	15	14.1	13.3	12.5	11.8	11.1	10.5	9.9	9.4	8.9	8.5	8.1	7.8	7.5	7.3
	P	0.4	0.7	1	1.3	1.6	1.9	2.2	2.5	2.8	3.1	3.3	3.6	3.9	4.2	4.5
	KTS 20-40 Q	19.5	18.6	17.8	17	16.3	15.6	15	14.4	13.9	13.4	13	12.6	12.3	12	11.8
	P	0.5	1	1.4	1.9	2.3	2.7	3.2	3.6	4.1	4.5	4.9	5.4	5.8	6.3	6.7
	KTS 25-34 Q	26.6	25.4	24.2	23.1	22.0	21.0	20.1	19.2	18.4	17.6	16.9	16.2	15.4	14.6	13.9
	P	0.7	1.2	1.8	2.3	2.8	3.4	3.9	4.5	5.0	5.6	6.1	6.7	7.2	7.8	8.3
	KTS 25-38 Q	29.7	28.7	27.7	26.8	25.9	25	24.2	23.4	22.7	22	21.4	20.8	20.2	19.7	19.3
	P	0.7	1.3	1.9	2.5	3.1	3.7	4.3	4.9	5.5	6.1	6.7	7.3	7.9	8.5	9.1
	KTS 25-50 Q	38.5	37.2	36	34.8	33.7	32.6	31.6	30.6	29.7	28.9	28.1	27.4	26.8	26.2	25.7
	P	1	1.7	2.5	3.3	4	4.8	5.6	6.3	7.1	7.9	8.7	9.4	10.2	11	11.7
	KTS 25-60 Q	45.2	43.8	42.3	41	39.8	38.6	37.5	36.4	35.5	34.6	33.8	33.1	32.4	31.8	31.4
	P	1.1	2	3	4	5	5.9	6.9	7.9	8.8	9.8	10.8	11.7	12.7	13.7	14.7
	KTS 32-48 Q	58.5	56.6	54.8	53.1	51.5	49.9	48.5	47.2	45.9	44.8	43.8	42.8	42	41.2	40.6
	P	1.4	2.5	3.7	4.8	6	7.2	8.3	9.5	10.6	11.8	13	14.1	15.3	16.4	17.6
	KTS 32-64 Q	79.4	77.2	75	72.9	70.9	69	67.2	65.5	63.8	62.3	60.8	59.5	58.2	57	55.9
	P	1.9	3.5	5	6.6	8.1	9.7	11.3	12.8	14.4	15.9	17.5	19.1	20.6	22.2	23.7
	KTS 32-76 Q	92.4	90.2	87.9	85.8	83.8	81.8	79.9	78	76.3	74.6	73	71.5	70	68.6	67.4
	P	2.3	4.2	6	7.9	9.7	11.6	13.4	15.3	17.1	19	20.8	22.7	24.5	26.4	28.2
	KTS 40-60 Q	115	112	109	106	103	100	97.6	95.1	92.8	90.5	88.4	86.3			
	P	2.8	4.9	7	9.1	11.2	13.3	15.4	17.5	19.6	21.7	23.8	25.9			
	KTS 40-80 Q	156	152	148	144	141	137	134	131	128	125	122	119			
	P	3.7	6.6	9.6	12.5	15.5	18.4	21.4	24.3	27.3	30.2	33.2	36.1			
	KTS 40-96 Q	187	183	179	175	171	167	164	160	157	154	151	148			
	P	4.4	8.1	11.8	15.5	19.3	23	26.7	30.5	34.2	37.9	41.7	45.4			
	KTS 50-74 Q	228	224	220	217	213	209	206	202	199	195	192	188			
	P	5	9.4	13.8	18.3	22.7	27.1	31.5	35.9	40.4	44.8	49.2	53.6			
	KTS 50-100 Q	311	305	300	294	289	284	279	274	270	266	261	257			
	P	7	13	19	25	31	37	43	49	55	61	67	73			
	KTS 50-120 Q	374	367	360	353	347	341	334	328	323	317	312	306			
	P	8.6	15.7	22.8	29.9	37	44.2	51.3	58.4	65.5	72.6	79.8	86.9			
	KTS 60-90 Q	458	447	436	425	415	405	396	387	378	369					
	P	10	18.3	26.6	34.9	43.2	51.5	59.8	68.1	76.4	84.7					
	KTS 60-120 Q	606	592	579	566	553	541	530	519							
	P	12	22.5	33	43.5	54	64.5	75	85.5							
	KTS 60-130 Q	651	639	627	614	602	590	578	567							
	P	13	24.2	35.4	46.6	57.8	69	80.2	91.5							
	KTS 60-145 Q	735	718	701	686	670	655									
	P	14.7	28.3	41.9	55.5	69.1	82.7									

Only characteristic values for the T design are shown; it is possible for other variants to feature different values.

Motor: 2-pole
 Speed: 2900 rpm
 Frequency: 50 Hz
 Flow rate: Q [l/min]
 Power demand: P [kW]
 Viscosity: 20 mm²/s, e.g. oil

2900 rpm
 50 Hz
 20 mm²/s

Viscosity > 20 mm²/s increased power demand. Higher pressures available on request.

Series	Pressure [bar]:		10	20	30	40	50	60	70	80	90	100	110	120	130	140	150
			KTS 20-30	Q	15.3	14.9	14.5	14.1	13.7	13.4	13.1	12.8	12.5	12.3	12.1	11.9	11.7
	P	0.4	0.7	1	1.3	1.6	1.9	2.2	2.5	2.8	3.1	3.3	3.6	3.9	4.2	4.5	
KTS 20-40	Q	20.2	19.7	19.3	18.9	18.6	18.2	17.9	17.6	17.4	17.1	16.9	16.7	16.6	16.4	16.3	
	P	0.5	1	1.4	1.9	2.3	2.7	3.2	3.6	4.1	4.5	4.9	5.4	5.8	6.3	6.7	
KTS 25-34	Q	27.5	26.6	25.7	24.9	24.2	23.5	22.9	22.3	21.8	20.9	20.4	19.9	19.4	19.0	18.5	
	P	0.7	1.2	1.8	2.3	2.8	3.4	3.9	4.5	5.0	5.6	6.1	6.7	7.2	7.8	8.3	
KTS 25-38	Q	30.4	29.8	29.3	28.9	28.4	28	27.6	27.2	26.8	26.5	26.2	25.9	25.6	25.4	25.1	
	P	0.7	1.3	1.9	2.5	3.1	3.7	4.3	4.9	5.5	6.1	6.7	7.3	7.9	8.5	9.1	
KTS 25-50	Q	39.7	39	38.4	37.8	37.2	36.7	36.2	35.7	35.3	34.8	34.5	34.1	33.8	33.5	33.2	
	P	1	1.7	2.5	3.3	4	4.8	5.6	6.3	7.1	7.9	8.7	9.4	10.2	11	11.7	
KTS 25-60	Q	47.1	46.3	45.6	45	44.3	43.8	43.2	42.7	42.2	41.8	41.4	41	40.7	40.4	40.1	
	P	1.1	2	3	4	5	5.9	6.9	7.9	8.8	9.8	10.8	11.7	12.7	13.7	14.7	
KTS 32-48	Q	61.3	60.4	59.5	58.6	57.8	57	56.3	55.7	55	54.5	54	53.5	53.1	52.7	52.4	
	P	1.4	2.5	3.7	4.8	6	7.2	8.3	9.5	10.6	11.8	13	14.1	15.3	16.4	17.6	
KTS 32-64	Q	82.5	81.4	80.3	79.2	78.2	77.3	76.4	75.5	74.7	73.9	73.2	72.5	71.9	71.3	70.7	
	P	1.9	3.5	5	6.6	8.1	9.7	11.3	12.8	14.4	15.9	17.5	19.1	20.6	22.2	23.7	
KTS 32-76	Q	97	95.9	94.8	93.7	92.7	91.7	90.7	89.8	88.9	88.1	87.3	86.5	85.8	85.1	84.5	
	P	2.3	4.2	6	7.9	9.7	11.6	13.4	15.3	17.1	19	20.8	22.7	24.5	26.4	28.2	
KTS 40-60	Q	120	118	117	115	114	113	111	110	109	108	107	106				
	P	2.8	4.9	7	9.1	11.2	13.3	15.4	17.5	19.6	21.7	23.8	25.9				
KTS 40-80	Q	161	160	158	156	154	152	151	149	147	146	144	143				
	P	3.7	6.6	9.6	12.5	15.5	18.4	21.4	24.3	27.3	30.2	33.2	36.1				
KTS 40-96	Q	194	192	190	188	186	184	182	180	179	177	176	174				
	P	4.4	8.1	11.8	15.5	19.3	23	26.7	30.5	34.2	37.9	41.7	45.4				
KTS 50-74	Q	235	233	231	229	227	225	224	222	220	218	216	215				
	P	5	9.4	13.8	18.3	22.7	27.1	31.5	35.9	40.4	44.8	49.2	53.6				
KTS 50-100	Q	319	316	313	310	308	305	303	300	298	296	294	292				
	P	7	13	19	25	31	37	43	49	55	61	67	73				
KTS 50-120	Q	383	379	376	372	369	366	363	360	357	354	352	349				
	P	8.6	15.7	22.8	29.9	37	44.2	51.3	58.4	65.5	72.6	79.8	86.9				
KTS 60-90	Q	464	458	453	448	443	438	433	428	424	419						
	P	10	18.3	26.6	34.9	43.2	51.5	59.8	68.1	76.4	84.7						
KTS 60-120	Q	609	601	595	588	582	576	570	565								
	P	12	22.5	33	43.5	54	64.5	75	85.5								
KTS 60-130	Q	655	648	642	636	630	624	618									
	P	13	24.2	35.4	46.6	57.8	69	80.2									
KTS 60-145	Q	746	737	729	721	714	706										
	P	14.7	28.3	41.9	55.5	69.1	82.7										

Only characteristic values for the T design are shown; it is possible for other variants to feature different values.

1450 rpm
50 Hz
1 mm²/s

Motor: 4-pole
Speed: 1450 rpm
Frequency: 50 Hz
Flow rate: Q [l/min]
Power demand: P [kW]
Viscosity: 1 mm²/s, e.g. emulsion

		Higher pressures available on request.														
Pressure [bar]:		10	20	30	40	50	60	70	80	90	100	110	120	130	140	150
Series	KTS 20-30 Q	7.1	6.3	5.4	4.7	3.9	3.3	2.6	2.1	1.5	1.1					
	P	0.2	0.4	0.5	0.7	0.8	0.9	1.1	1.2	1.4	1.5					
	KTS 20-40 Q	9	8.2	7.3	6.6	5.8	5.2	4.5	4	3.4	3					
	P	0.3	0.5	0.7	0.9	1.2	1.4	1.6	1.8	2	2.3					
	KTS 25-34 Q	12.3	10.8	9.4	8.3	7.4	6.6	5.8	5.0	4.2	3.4					
	P	0.4	0.7	0.9	1.2	1.5	1.8	2.0	2.3	2.6	2.9					
	KTS 25-38 Q	14.2	13.2	12.2	11.3	10.4	9.5	8.7	7.9	7.2	6.5					
	P	0.4	0.7	1	1.3	1.6	1.9	2.2	2.5	2.8	3.1					
	KTS 25-50 Q	18.1	16.8	15.6	14.4	13.3	12.2	11.2	10.2	9.3	8.5					
	P	0.5	0.9	1.2	1.6	2	2.4	2.8	3.2	3.6	3.9					
	KTS 25-60 Q	20.8	19.3	17.9	16.5	15.3	14.1	13	12	11	10.1					
	P	0.5	1	1.5	2	2.5	3	3.4	3.9	4.4	4.9					
	KTS 32-48 Q	26.4	24.5	22.7	21	19.4	17.9	16.4	15.1	13.9	12.7					
	P	0.7	1.3	1.8	2.4	3	3.6	4.2	4.7	5.3	5.9					
	KTS 32-64 Q	36.7	34.4	32.2	30.2	28.2	26.3	24.4	22.7	21.1	19.5					
	P	1	1.7	2.5	3.3	4.1	4.9	5.6	6.4	7.2	8					
	KTS 32-76 Q	41.7	39.4	37.2	35	33	31	29.1	27.3	25.5	23.8					
	P	1.2	2.1	3	3.9	4.9	5.8	6.7	7.6	8.6	9.5					
	KTS 40-60 Q	52.1	49	46	43	40.2	37.5	35	32.5	30.1	27.9					
	P	1.4	2.5	3.5	4.6	5.6	6.7	7.7	8.8	9.8	10.9					
	KTS 40-80 Q	72.4	68.5	64.7	61	57.4	53.9	50.5	47.2	44	41					
	P	1.8	3.3	4.8	6.3	7.7	9.2	10.7	12.2	13.6	15.1					
	KTS 40-96 Q	87.3	82.9	78.7	74.6	70.7	66.9	63.3	59.9	56.6	53.5					
	P	2.2	4	5.9	7.8	9.6	11.5	13.4	15.2	17.1	19					
	KTS 50-74 Q	107	104	99.8	96	92.3	88.6	85	81.4	77.8	74.3					
	P	2.5	4.7	6.9	9.1	11.3	13.6	15.8	18	20.2	22.4					
	KTS 50-100 Q	148	142	137	131	126	121	116	111	107	102					
	P	3.5	6.5	9.5	12.5	15.5	18.5	21.5	24.5	27.5	30.5					
	KTS 50-120 Q	178	171	164	158	151	145	139	133	127	121					
	P	4.3	7.8	11.4	15	18.5	22.1	25.6	29.2	32.8	36.3					
	KTS 60-90 Q	223	212	201	191	180	171	161	152							
	P	5	9.2	13.3	17.5	21.6	25.8	29.9	34.1							
	KTS 60-120 Q	301	287	273	260	248	236	225	214							
	P	6	11.3	16.5	21.8	27	32.3	37.5	42.8							
	KTS 60-130 Q	323	310	298	286	273	261	250	238							
	P	6.5	12.1	17.7	23.3	28.9	34.5	40.1	45.7							
	KTS 60-145 Q	356	339	323	307	292	277	263	249							
	P	7.4	14.2	21	27.8	34.6	41.4	48.2	55							

Only characteristic values for the T design are shown; it is possible for other variants to feature different values.

Motor: 4-pole
 Speed: 1450 rpm
 Frequency: 50 Hz
 Flow rate: Q [l/min]
 Power demand: P [kW]
 Viscosity: 20 mm²/s, e.g. oil

1450 rpm
 50 Hz
 20 mm²/s

Viscosity > 20 mm²/s increased power demand. Higher pressures available on request.

Series	Pressure [bar]:		10	20	30	40	50	60	70	80	90	100	110	120	130	140	150
			KTS 20-30	Q	7.5	7.1	6.6	6.3	5.9	5.6	5.2	5	4.7	4.5			
	P	0.2	0.4	0.5	0.7	0.8	0.9	1.1	1.2	1.4	1.5						
KTS 20-40	Q	9.7	9.3	8.9	8.5	8.1	7.8	7.5	7.2	6.9	6.7						
	P	0.3	0.5	0.7	0.9	1.2	1.4	1.6	1.8	2	2.3						
KTS 25-34	Q	13.1	11.9	11.0	10.1	9.5	9.0	8.4	7.9	7.4	6.9						
	P	0.4	0.7	0.9	1.2	1.5	1.8	2.0	2.3	2.6	2.9						
KTS 25-38	Q	14.9	14.3	13.8	13.4	12.9	12.5	12.1	11.7	11.3	11						
	P	0.4	0.7	1	1.3	1.6	1.9	2.2	2.5	2.8	3.1						
KTS 25-50	Q	19.3	18.6	18	17.4	16.8	16.3	15.8	15.3	14.9	14.5						
	P	0.5	0.9	1.2	1.6	2	2.4	2.8	3.2	3.6	3.9						
KTS 25-60	Q	22.6	21.9	21.2	20.5	19.9	19.3	18.7	18.2	17.7	17.3						
	P	0.5	1	1.5	2	2.5	3	3.4	3.9	4.4	4.9						
KTS 32-48	Q	29.2	28.3	27.4	26.5	25.7	25	24.3	23.6	23	22.4						
	P	0.7	1.3	1.8	2.4	3	3.6	4.2	4.7	5.3	5.9						
KTS 32-64	Q	39.7	38.6	37.5	36.5	35.5	34.5	33.6	32.7	31.9	31.2						
	P	1	1.7	2.5	3.3	4.1	4.9	5.6	6.4	7.2	8						
KTS 32-76	Q	46.2	45.1	44	42.9	41.9	40.9	39.9	39	38.1	37.3						
	P	1.2	2.1	3	3.9	4.9	5.8	6.7	7.6	8.6	9.5						
KTS 40-60	Q	57.4	55.8	54.3	52.8	51.4	50.1	48.8	47.6	46.4	45.3						
	P	1.4	2.5	3.5	4.6	5.6	6.7	7.7	8.8	9.8	10.9						
KTS 40-80	Q	78	76	74.1	72.2	70.4	68.7	67	65.4	63.8	62.3						
	P	1.8	3.3	4.8	6.3	7.7	9.2	10.7	12.2	13.6	15.1						
KTS 40-96	Q	93.7	91.6	89.5	87.4	85.5	83.6	81.8	80.1	78.4	76.9						
	P	2.2	4	5.9	7.8	9.6	11.5	13.4	15.2	17.1	19						
KTS 50-74	Q	114	112	110	108	107	105	103	101	99.3	97.5						
	P	2.5	4.7	6.9	9.1	11.3	13.6	15.8	18	20.2	22.4						
KTS 50-100	Q	156	153	150	147	145	142	140	137	135	133						
	P	3.5	6.5	9.5	12.5	15.5	18.5	21.5	24.5	27.5	30.5						
KTS 50-120	Q	187	184	180	177	173	170	167	164	161	159						
	P	4.3	7.8	11.4	15	18.5	22.1	25.6	29.2	32.8	36.3						
KTS 60-90	Q	229	223	218	213	208	203	198	193								
	P	5	9.2	13.3	17.5	21.6	25.8	29.9	34.1								
KTS 60-120	Q	303	296	289	283	277	271	265	260								
	P	6	11.3	16.5	21.8	27	32.3	37.5	42.8								
KTS 60-130	Q	326	320	313	307	301	295	289	283								
	P	6.5	12.1	17.7	23.3	28.9	34.5	40.1	45.7								
KTS 60-145	Q	367	359	351	343	335	328	321	314								
	P	7.4	14.2	21	27.8	34.6	41.4	48.2	55								

Only characteristic values for the T design are shown; it is possible for other variants to feature different values.

3500 rpm
60 Hz
1 mm²/s

Motor: 2-pole
Speed: 3500 rpm
Frequency: 60 Hz
Flow rate: Q [l/min]
Power demand: P [kW]
Viscosity: 1 mm²/s, e.g. emulsion

		Higher pressures available on request.														
Pressure [bar]:		10	20	30	40	50	60	70	80	90	100	110	120	130	140	150
Series	KTS 20-30 Q	18.2	17.3	16.5	15.7	15	14.3	13.7	13.1	12.6	12.1	11.7	11.3	11	10.7	10.5
	P	0.5	0.9	1.2	1.6	1.9	2.3	2.6	3	3.3	3.7	4	4.4	4.7	5.1	5.4
	KTS 20-40 Q	23.8	22.9	22.1	21.3	20.6	19.9	19.3	18.7	18.2	17.7	17.3	16.9	16.6	16.3	16.1
	P	0.7	1.2	1.7	2.2	2.8	3.3	3.8	4.4	4.9	5.4	6	6.5	7	7.6	8.1
	KTS 25-34 Q	32.6	31.4	30.2	29.0	27.9	26.9	25.9	25.0	24.1	23.3	22.6	21.9	21.3	20.8	20.3
	P	0.8	1.5	2.1	2.7	3.4	4.0	4.7	5.3	5.9	6.6	7.2	7.8	8.5	9.1	9.8
	KTS 25-38 Q	36.1	35.1	34.1	33.2	32.3	31.4	30.6	29.8	29.1	28.4	27.8	27.2	26.6	26.1	25.7
	P	0.8	1.6	2.3	3	3.7	4.5	5.2	5.9	6.6	7.4	8.1	8.8	9.5	10.3	11
	KTS 25-50 Q	47	45.7	44.4	43.2	42.1	41	40	39.1	38.2	37.3	36.6	35.9	35.2	34.6	34.1
	P	1.1	2.1	3	3.9	4.9	5.8	6.7	7.7	8.6	9.5	10.4	11.4	12.3	13.2	14.2
	KTS 25-60 Q	55.4	53.9	52.5	51.1	49.9	48.7	47.6	46.6	45.6	44.7	43.9	43.2	42.5	42	41.5
	P	1.3	2.5	3.6	4.8	6	7.1	8.3	9.5	10.7	11.8	13	14.2	15.3	16.5	17.7
	KTS 32-48 Q	71.8	69.9	68.1	66.3	64.7	63.2	61.8	60.4	59.2	58.1	57	56.1	55.2	54.5	53.8
	P	1.6	3	4.4	5.8	7.2	8.6	10	11.4	12.8	14.2	15.6	17	18.4	19.8	21.2
	KTS 32-64 Q	97.1	94.9	92.7	90.6	88.6	86.7	84.9	83.2	81.5	80	78.5	77.2	75.9	74.7	73.6
	P	2.3	4.2	6.1	7.9	9.8	11.7	13.6	15.5	17.4	19.2	21.1	23	24.9	26.8	28.7
	KTS 32-76 Q	113	111	109	107	105	103	101	99	97.3	95.6	94	92.5	91	89.7	88.4
	P	2.8	5	7.2	9.5	11.7	13.9	16.2	18.4	20.6	22.9	25.1	27.3	29.6	31.8	34
	KTS 40-60 Q	141	138	135	132	129	126	124	121	119	116	114	112			
	P	3.4	6	8.5	11	13.6	16.1	18.6	21.2	23.7	26.2	28.8	31.3			
	KTS 40-80 Q	191	187	183	179	175	172	169	165	162	159	156	153			
	P	4.4	8	11.5	15.1	18.7	22.2	25.8	29.3	32.9	36.5	40	43.6			
	KTS 40-96 Q	229	225	220	216	212	209	205	202	198	195	192	189			
	P	5.3	9.8	14.3	18.8	23.3	27.8	32.3	36.8	41.3	45.8	50.3	54.8			
	KTS 50-74 Q	278	274	270	267	263	259	256	252	248	245	241	238			
	P	6	11.4	16.7	22	27.4	32.7	38	43.4	48.7	54	59.4	64.7			
	KTS 50-100 Q	379	373	367	362	357	352	347	342	337	333	329	325			
	P	8.4	15.7	22.9	30.2	37.4	44.7	51.9	59.1	66.4	73.6	80.9	88.1			
	KTS 50-120 Q	455	448	441	434	428	422	415	409	404	398					
	P	10.3	18.9	27.5	36.1	44.7	53.3	61.9	70.5	79.1	87.7					
	KTS 60-90 Q	555	544	533	523	512	503	493	484							
	P	12.1	22.1	32.1	42.1	52.1	62.2	72.2	82.2							
	KTS 60-120 Q	733	719	705	692	679	668									
	P	14.5	27.2	39.8	52.5	65.2	77.8									
	KTS 60-130 Q	788	775	763	751	738	726									
	P	15.7	29.2	42.7	56.2	69.8	83.3									
	KTS 60-145 Q	891	874	858	842	827										
	P	17.7	34.2	50.6	67	83.4										

The KTS 60-130 and KTS 60-145 must be operated with a supply pressure of at least 1.5 bar at a speed of 3500 rpm.

Only characteristic values for the T design are shown; it is possible for other variants to feature different values.

Motor: 2-pole
 Speed: 3500 rpm
 Frequency: 60 Hz
 Flow rate: Q [l/min]
 Power demand: P [kW]
 Viscosity: 20 mm²/s, e.g. oil

3500 rpm
 60 Hz
 20 mm²/s

Viscosity > 20 mm²/s increased power demand. Higher pressures available on request.

Series	Pressure [bar]:	10	20	30	40	50	60	70	80	90	100	110	120	130	140	150
		KTS 20-30	Q	18.6	18.1	17.7	17.3	17	16.6	16.3	16	15.8	15.5	15.3	15.1	15
	P	0.5	0.9	1.2	1.6	1.9	2.3	2.6	3	3.3	3.7	4	4.4	4.7	5.1	5.4
KTS 20-40	Q	24.5	24.1	23.6	23.3	22.9	22.6	22.2	22	21.7	21.5	21.2	21.1	20.9	20.8	20.6
	P	0.7	1.2	1.7	2.2	2.8	3.3	3.8	4.4	4.9	5.4	6	6.5	7	7.6	8.1
KTS 25-34	Q	33.5	32.6	31.7	30.9	30.1	29.4	28.8	28.2	27.7	26.8	26.3	25.8	25.3	24.8	24.3
	P	0.8	1.5	2.1	2.7	3.4	4.0	4.7	5.3	5.9	6.6	7.2	7.8	8.5	9.1	9.8
KTS 25-38	Q	36.8	36.3	35.8	35.3	34.8	34.4	34	33.6	33.3	32.9	32.6	32.3	32	31.8	31.5
	P	0.8	1.6	2.3	3	3.7	4.5	5.2	5.9	6.6	7.4	8.1	8.8	9.5	10.3	11
KTS 25-50	Q	48.1	47.4	46.8	46.2	45.7	45.1	44.6	44.1	43.7	43.3	42.9	42.5	42.2	41.9	41.7
	P	1.1	2.1	3	3.9	4.9	5.8	6.7	7.7	8.6	9.5	10.4	11.4	12.3	13.2	14.2
KTS 25-60	Q	57.2	56.5	55.8	55.1	54.5	53.9	53.3	52.8	52.3	51.9	51.5	51.1	50.8	50.5	50.3
	P	1.3	2.5	3.6	4.8	6	7.1	8.3	9.5	10.7	11.8	13	14.2	15.3	16.5	17.7
KTS 32-48	Q	74.6	73.6	72.7	71.9	71.1	70.3	69.6	68.9	68.3	67.7	67.2	66.8	66.3	66	65.6
	P	1.6	3	4.4	5.8	7.2	8.6	10	11.4	12.8	14.2	15.6	17	18.4	19.8	21.2
KTS 32-64	Q	100	99	98	96.9	95.9	95	94.1	93.2	92.4	91.6	90.9	90.2	89.6	89	88.4
	P	2.3	4.2	6.1	7.9	9.8	11.7	13.6	15.5	17.4	19.2	21.1	23	24.9	26.8	28.7
KTS 32-76	Q	118	117	116	115	114	113	112	111	110	109	108	108	107	106	105
	P	2.8	5	7.2	9.5	11.7	13.9	16.2	18.4	20.6	22.9	25.1	27.3	29.6	31.8	34
KTS 40-60	Q	146	144	143	141	140	139	137	136	135	134	133	132			
	P	3.4	6	8.5	11	13.6	16.1	18.6	21.2	23.7	26.2	28.8	31.3			
KTS 40-80	Q	196	194	192	190	189	187	185	183	182	180	179	177			
	P	4.4	8	11.5	15.1	18.7	22.2	25.8	29.3	32.9	36.5	40	43.6			
KTS 40-96	Q	235	233	231	229	227	225	223	222	220	219	217	216			
	P	5.3	9.8	14.3	18.8	23.3	27.8	32.3	36.8	41.3	45.8	50.3	54.8			
KTS 50-74	Q	285	283	281	279	277	275	274	272	270	268	266	265			
	P	6	11.4	16.7	22	27.4	32.7	38	43.4	48.7	54	59.4	64.7			
KTS 50-100	Q	386	383	381	378	375	373	370	368	366	363	361	359			
	P	8.4	15.7	22.9	30.2	37.4	44.7	51.9	59.1	66.4	73.6	80.9	88.1			
KTS 50-120	Q	464	460	457	453	450	447	444	441	438	435					
	P	10.3	18.9	27.5	36.1	44.7	53.3	61.9	70.5	79.1	87.7					
KTS 60-90	Q	561	555	550	545	540	535	530	525							
	P	12.1	22.1	32.1	42.1	52.1	62.2	72.2	82.2							
KTS 60-120	Q	735	728	721	715	708	702									
	P	14.5	27.2	39.8	52.5	65.2	77.8									
KTS 60-130	Q	791	784	778	772	766	760									
	P	15.7	29.2	42.7	56.2	69.8	83.3									
KTS 60-145	Q	902	894	886	878	870										
	P	17.7	34.2	50.6	67	83.4										

The KTS 60-130 and KTS 60-145 must be operated with a supply pressure of at least 1.5 bar at a speed of 3500 rpm. Only characteristic values for the T design are shown; it is possible for other variants to feature different values.

1750 rpm
60 Hz
1 mm²/s

Motor: 4-pole
Speed: 1750 rpm
Frequency: 60 Hz
Flow rate: Q [l/min]
Power demand: P [kW]
Viscosity: 1 mm²/s, e.g. emulsion

		Higher pressures available on request.														
Pressure [bar]:		10	20	30	40	50	60	70	80	90	100	110	120	130	140	150
Series	KTS 20-30 Q	8.8	7.9	7.1	6.3	5.6	4.9	4.3	3.7	3.2	2.7					
	P	0.3	0.4	0.6	0.8	1	1.1	1.3	1.5	1.7	1.8					
	KTS 20-40 Q	11.2	10.3	9.5	8.7	8	7.3	6.7	6.1	5.6	5.1					
	P	0.3	0.6	0.9	1.1	1.4	1.7	1.9	2.2	2.5	2.7					
	KTS 25-34 Q	15.2	13.8	12.5	11.3	10.2	9.2	8.4	7.7	7.1	6.3					
	P	0.4	0.8	1.1	1.4	1.8	2.1	2.4	2.8	3.1	3.4					
	KTS 25-38 Q	17.4	16.4	15.4	14.5	13.6	12.7	11.9	11.1	10.4	9.7					
	P	0.4	0.8	1.1	1.5	1.9	2.2	2.6	3	3.3	3.7					
	KTS 25-50 Q	22.4	21	19.8	18.6	17.5	16.4	15.4	14.4	13.6	12.7					
	P	0.6	1	1.5	2	2.4	2.9	3.4	3.8	4.3	4.8					
	KTS 25-60 Q	25.8	24.3	22.9	21.6	20.3	19.2	18.1	17	16.1	15.2					
	P	0.6	1.2	1.8	2.4	3	3.6	4.2	4.7	5.3	5.9					
	KTS 32-48 Q	33.1	31.2	29.3	27.6	26	24.5	23.1	21.7	20.5	19.4					
	P	0.8	1.5	2.2	2.9	3.6	4.3	5	5.7	6.4	7.1					
	KTS 32-64 Q	45.5	43.3	41.1	39	37	35.1	33.3	31.6	29.9	28.4					
	P	1.1	2.1	3	4	4.9	5.9	6.8	7.7	8.7	9.6					
	KTS 32-76 Q	52.2	49.9	47.7	45.5	43.5	41.5	39.6	37.8	36	34.3					
	P	1.4	2.5	3.6	4.7	5.9	7	8.1	9.2	10.3	11.4					
	KTS 40-60 Q	65.1	61.9	58.9	56	53.2	50.5	47.9	45.4	43.1	40.8					
	P	1.7	3	4.2	5.5	6.8	8.1	9.3	10.6	11.9	13.1					
	KTS 40-80 Q	89.7	85.8	82	78.2	74.6	71.1	67.8	64.5	61.3	58.3					
	P	2.2	4	5.8	7.5	9.3	11.1	12.9	14.7	16.5	18.2					
	KTS 40-96 Q	108	104	99.4	95.3	91.4	87.7	84.1	80.6	77.3	74.2					
	P	2.6	4.9	7.1	9.4	11.6	13.9	16.1	18.4	20.6	22.9					
	KTS 50-74 Q	132	129	125	121	117	114	110	106	103	99.3					
	P	3	5.7	8.4	11	13.7	16.4	19	21.7	24.4	27					
	KTS 50-100 Q	182	176	170	165	160	155	150	145	141	136					
	P	4.2	7.8	11.5	15.1	18.7	22.3	25.9	29.6	33.2	36.8					
	KTS 50-120 Q	219	212	205	198	192	185	179	173	167	162					
	P	5.2	9.5	13.8	18	22.3	26.6	30.9	35.2	39.5	43.8					
	KTS 60-90 Q	271	260	250	239	229	219	210	200							
	P	6	11	16.1	21.1	26.1	31.1	36.1	41.1							
	KTS 60-120 Q	364	350	336	323	311	299	288	277							
	P	7.2	13.6	19.9	26.3	32.6	38.9	45.3	51.6							
	KTS 60-130 Q	391	378	366	354	342	329	318	306							
	P	7.8	14.6	21.4	28.1	34.9	41.6	48.4	55.2							
	KTS 60-145 Q	435	418	401	385	370	355	341	327							
	P	8.9	17.1	25.3	33.5	41.7	49.9	58.1	66.3							

Only characteristic values for the T design are shown; it is possible for other variants to feature different values.

Motor: 4-pole
 Speed: 1750 rpm
 Frequency: 60 Hz
 Flow rate: Q [l/min]
 Power demand: P [kW]
 Viscosity: 20 mm²/s, e.g. oil

1750 rpm
 60 Hz
 20 mm²/s

Viscosity > 20 mm²/s increased power demand. Higher pressures available on request.

Series	Pressure [bar]:		10	20	30	40	50	60	70	80	90	100	110	120	130	140	150
			KTS 20-30	Q	9.1	8.7	8.3	7.9	7.5	7.2	6.9	6.6	6.3	6.1			
	P	0.3	0.4	0.6	0.8	1	1.1	1.3	1.5	1.7	1.8						
KTS 20-40	Q	11.9	11.5	11	10.7	10.3	10	9.6	9.4	9.1	8.9						
	P	0.3	0.6	0.9	1.1	1.4	1.7	1.9	2.2	2.5	2.7						
KTS 25-34	Q	16.1	15.0	14.0	13.2	12.5	11.9	11.4	10.8	10.3	9.9						
	P	0.4	0.8	1.1	1.4	1.8	2.1	2.4	2.8	3.1	3.4						
KTS 25-38	Q	18.1	17.6	17.1	16.6	16.1	15.7	15.3	14.9	14.5	14.2						
	P	0.4	0.8	1.1	1.5	1.9	2.2	2.6	3	3.3	3.7						
KTS 25-50	Q	23.5	22.8	22.2	21.6	21	20.5	20	19.5	19.1	18.7						
	P	0.6	1	1.5	2	2.4	2.9	3.4	3.8	4.3	4.8						
KTS 25-60	Q	27.7	26.9	26.2	25.6	24.9	24.3	23.8	23.3	22.8	22.4						
	P	0.6	1.2	1.8	2.4	3	3.6	4.2	4.7	5.3	5.9						
KTS 32-48	Q	35.9	34.9	34	33.2	32.4	31.6	30.9	30.2	29.6	29						
	P	0.8	1.5	2.2	2.9	3.6	4.3	5	5.7	6.4	7.1						
KTS 32-64	Q	48.6	47.4	46.4	45.3	44.3	43.4	42.5	41.6	40.8	40						
	P	1.1	2.1	3	4	4.9	5.9	6.8	7.7	8.7	9.6						
KTS 32-76	Q	56.7	55.6	54.5	53.4	52.4	51.4	50.4	49.5	48.6	47.8						
	P	1.4	2.5	3.6	4.7	5.9	7	8.1	9.2	10.3	11.4						
KTS 40-60	Q	70.3	68.8	67.3	65.8	64.4	63.1	61.8	60.5	59.3	58.2						
	P	1.7	3	4.2	5.5	6.8	8.1	9.3	10.6	11.9	13.1						
KTS 40-80	Q	95.3	93.3	91.4	89.5	87.7	86	84.3	82.6	81.1	79.5						
	P	2.2	4	5.8	7.5	9.3	11.1	12.9	14.7	16.5	18.2						
KTS 40-96	Q	114	112	110	108	106	104	103	101	99.2	97.6						
	P	2.6	4.9	7.1	9.4	11.6	13.9	16.1	18.4	20.6	22.9						
KTS 50-74	Q	139	137	135	133	131	130	128	126	124	122						
	P	3	5.7	8.4	11	13.7	16.4	19	21.7	24.4	27						
KTS 50-100	Q	189	186	184	181	178	176	173	171	169	167						
	P	4.2	7.8	11.5	15.1	18.7	22.3	25.9	29.6	33.2	36.8						
KTS 50-120	Q	228	224	221	217	214	211	208	205	202	199						
	P	5.2	9.5	13.8	18	22.3	26.6	30.9	35.2	39.5	43.8						
KTS 60-90	Q	277	272	267	261	256	251	247	242								
	P	6	11	16.1	21.1	26.1	31.1	36.1	41.1								
KTS 60-120	Q	366	359	352	346	340	334	328	323								
	P	7.2	13.6	19.9	26.3	32.6	38.9	45.3	51.6								
KTS 60-130	Q	394	388	381	375	369	363	357	351								
	P	7.8	14.6	21.4	28.1	34.9	41.6	48.4	55.2								
KTS 60-145	Q	446	437	429	421	413	406	399	392								
	P	8.9	17.1	25.3	33.5	41.7	49.9	58.1	66.3								

Only characteristic values for the T design are shown; it is possible for other variants to feature different values.

Speed control with PQ-Tronic

Function

Knoll PQ-Tronic enables users to specify any pressure level within the 0 to 150 bar range. This system automatically controls the pump performance. Changing the drive motor between 10 Hz – 75 Hz causes the speeds of the pump unit to change (500 – 4500 rpm) and therefore also changes the characteristic curves. A pressure sensor combined with an electronic PI control guarantees the specified pressure (setpoint) regardless of the consumption.

Application

- Machine tools, machining centres and associated tools with internal coolant supply

Benefits

- Any pressure level can be selected via the M function
- Energy savings between 50% and 70%, resulting in a rapid return on investment
- Low-pulsation supply
- Soft starts and stops
- No start-up current peaks
- Speed adaptation minimises noise
- Minimal wear and maintenance requirements
- High pump service life because parameters are designed to optimally suit the process
- Heat transfer to the medium is reduced thanks to performance adaptations, therefore enabling the use of a smaller cooler
- Minimum quantities with vario valve at minimum speed
- Vario valve as a safety valve with offset for the operating pressure

Schematic diagram

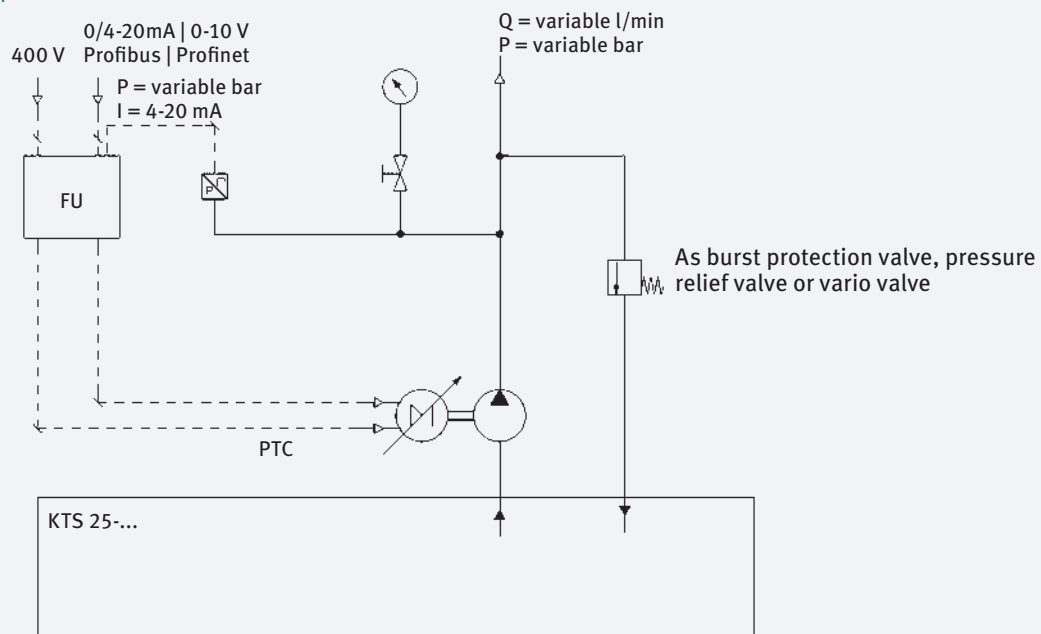

Example design

Customer requirement

Medium: emulsion

Viscosity: 1 mm²/s

Max. pressure increase.: 80 bar

Flow rate: 19 l/min

Speed control with PQ-Tronic

Design

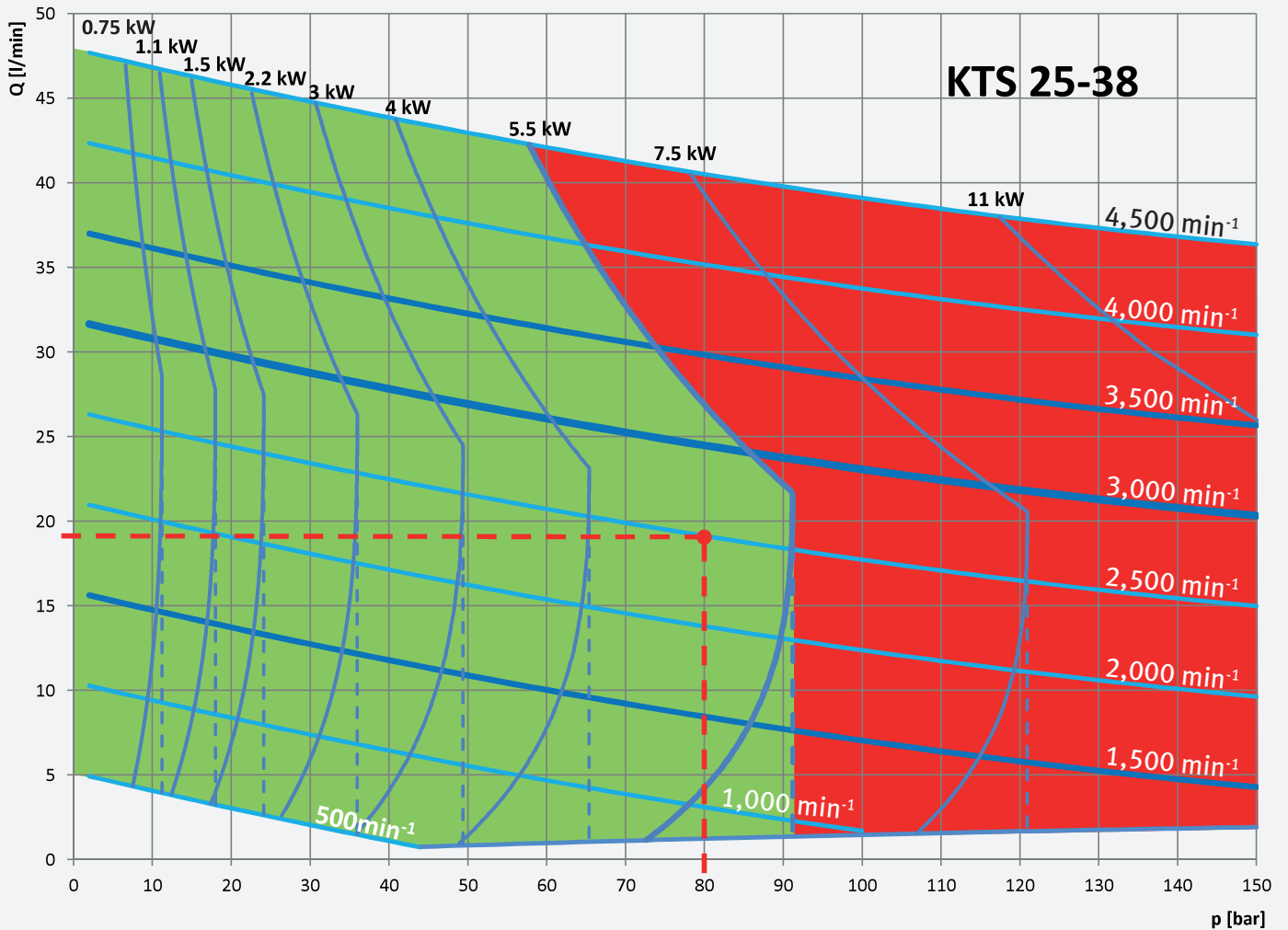

Result for the three-phase motor

Power: 5.5 kW

Speed: 2500 rpm

Number of poles: 2

Uses

Within the diagram, every operating point to the left of the motor characteristic curve (green area) is possible with regards to flow rate and pressure. The motor output characteristic curve is calculated from the torque available at a given pressure. For several operating points, the pump size has been optimally designed for the power level.

Pressure control comparison

Energy savings for machining a gearbox housing, calculated based on the energy required to supply cooling lubricant.

Constant and uncontrolled pressure (pressure relief valve)

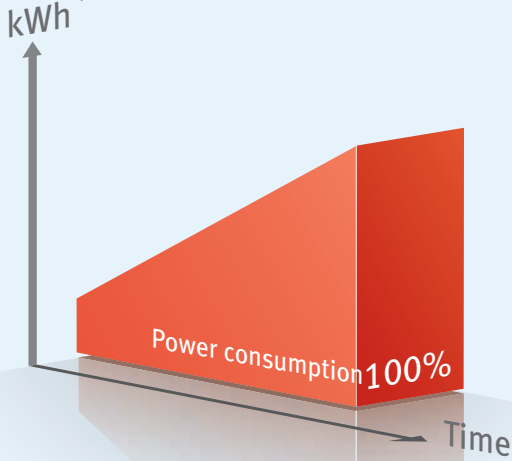

- Constant pressure, e.g. 90 bar
- Constant speed
- Constant valve setting of 90 bar

Conclusion

Highest power consumption, lowest procurement costs

Constant pressure and minimised outflow pressure

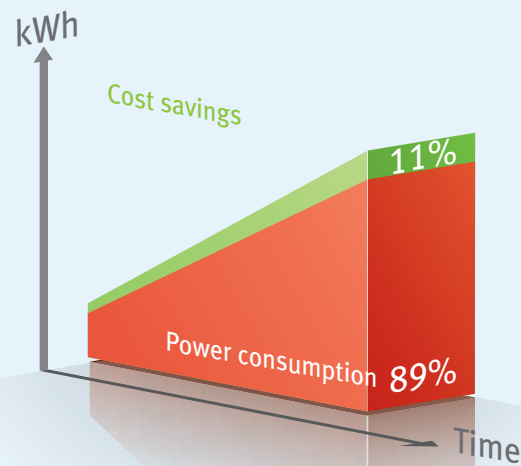

- Constant pressure, e.g. 90 bar
- Constant speed
- Valve setting of 90 bar, opened during pauses

Conclusion

Low energy savings, low procurement costs

Variable pressure and minimised outflow pressure

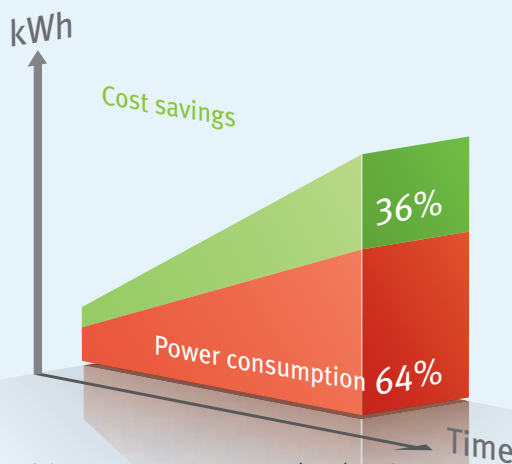

- Variable pressure, e.g. 30/60/90 bar
- Constant speed
- Pressures are activated

Conclusion

Moderate energy savings, moderate procurement costs, quick return on investment

Variable pressure with speed adjustment (PQ-Tronic)

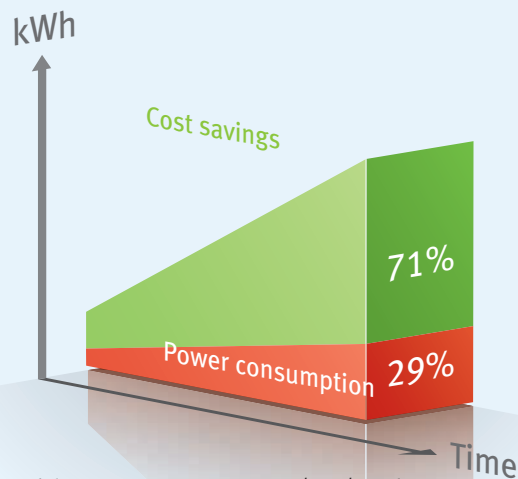

- Variable pressure, e.g. 30/60/90 bar
- Variable speed via frequency inverter

Conclusion

Highest energy savings, highest procurement costs, fastest return on investment

ENERGYNOW

KNOLL
.It works

We determine
your possible
energy savings
on-site

Guaranteed!

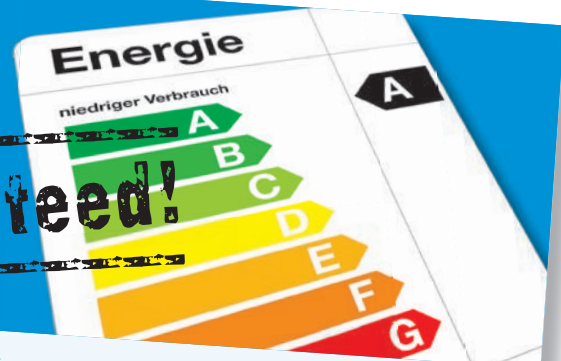

So far, not many customers opted for our energy saving PQ-Tronic control technology because the determination of the possible savings was too complex.

NOW the measuring process is fast and simple

KNOLLE-PASS

1. We can determine your energy-saving potential on site with a brief measurement, followed by a computer calculation. Afterwards, you receive your energy protocol.
2. Additionally, we provide you with an on-site cost/benefit appraisal, including your amortization analysis.
3. You then decide whether to go for a PQ-Tronic upgrade.

If you wish to obtain more detailed information, please contact us.

Florian Schönbacher, energy-efficient solutions

Tel.: +49 7581 2008-91254

Fax: +49 7581 2008-90151

E-Mail: florian.schoenbacher@knoll-mb.de

KNOLL Maschinenbau GmbH
Schwarzachstraße 20
DE-88348 Bad Saulgau
www.knoll-mb.com

Cooling lubricant volume flow

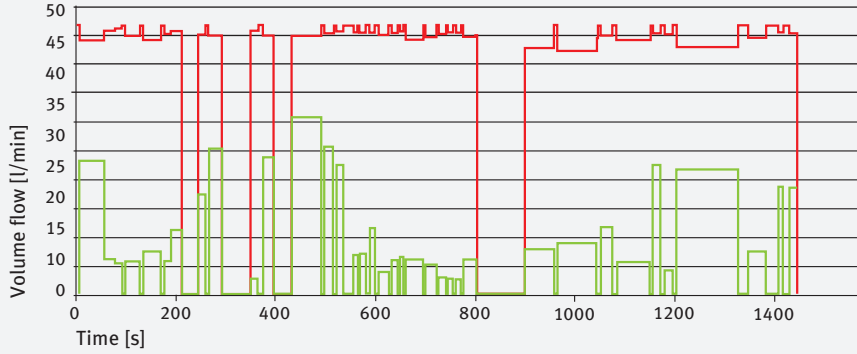

- Volume flow without control
- Volume flow with control

PQ-Tronic pressure curve

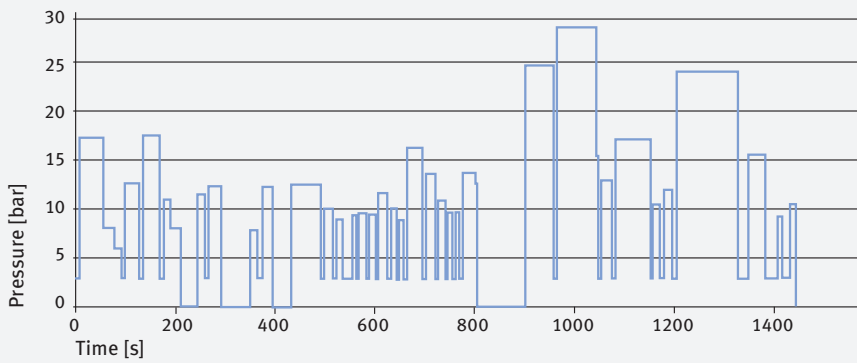

- Pressure curve

Power consumption (pump and cooler)

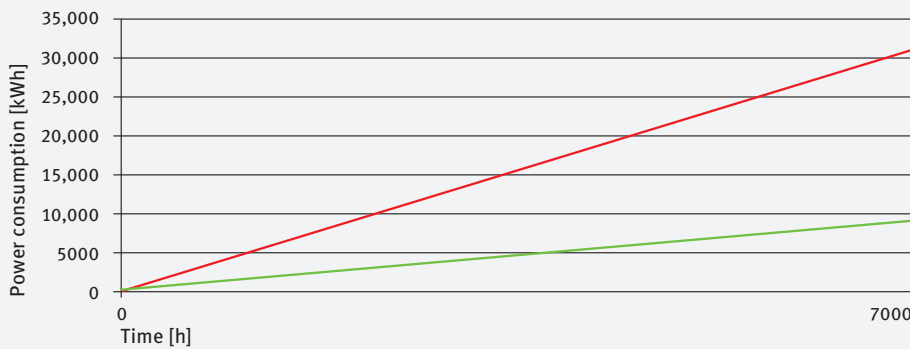

- Power consumption without control: 100%
- Power consumption with control: 28.3%

Return on investment (7000 operating hours per year)

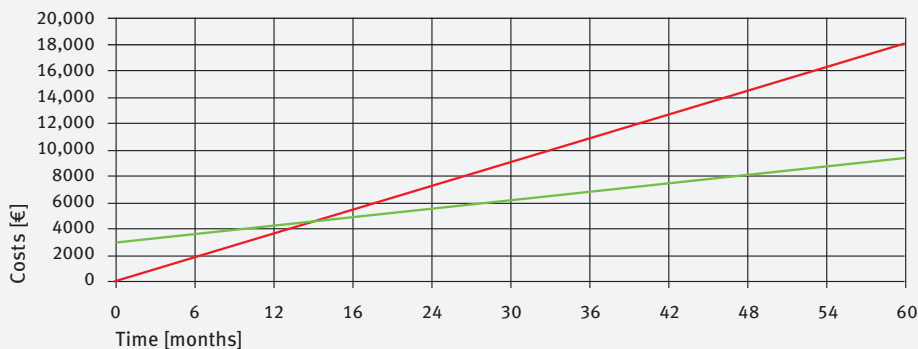

- Costs without control
- Costs with control

Case study

For one of the most significant system suppliers of gear technology for cars and light commercial vehicles worldwide, environmental protection is an important theme in two respects: Firstly, their products should contribute to making cars more environmentally friendly, and secondly, their product managers work to keep their own environmental footprint small. Consequently, all processes are constantly checked and optimised for cost-effectiveness, energy and resource efficiency and environmental sustainability.

The KNOLL E-PASS provided customers with an analysis of the current situation and a calculation of potential savings, including a calculation of return on investment. The evaluations were provided in graphical and tabular form.

The customer added the KNOLL PQ-Tronic frequency control to their original high-pressure pump with pressure relief valve.

KNOLL implemented the entire process of connecting the frequency control to an existing machine tool, including electrical and control system connections and the necessary safety considerations.

Result: The reference system confirmed the theoretically determined values. Full return on investment was achieved in under 2 years.

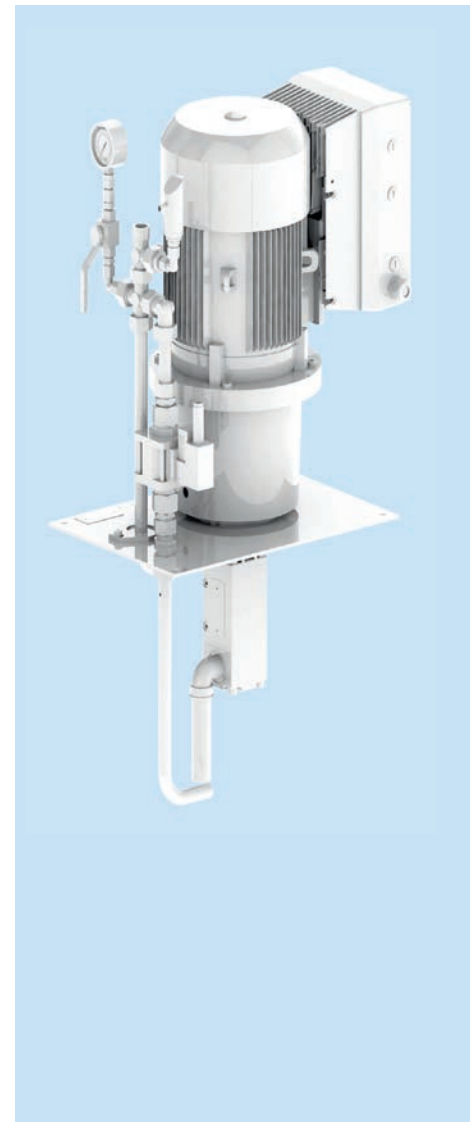

Process monitoring with PQ-Tronic



The KTS for deep drilling with PQ-Tronic

KNOLL uses the data from the frequency inverter to detect signs of imminent tool breakage. Corresponding signals are relayed to the CNC control unit so that the operator or the machine can intervene in the process early enough.

Customer benefits

- Higher feed rates
- Higher process reliability
- Reduced reject rate
- Reduced tool costs
- Early detection of tool wear
- Higher system availability
- Energy savings
- Increased productivity

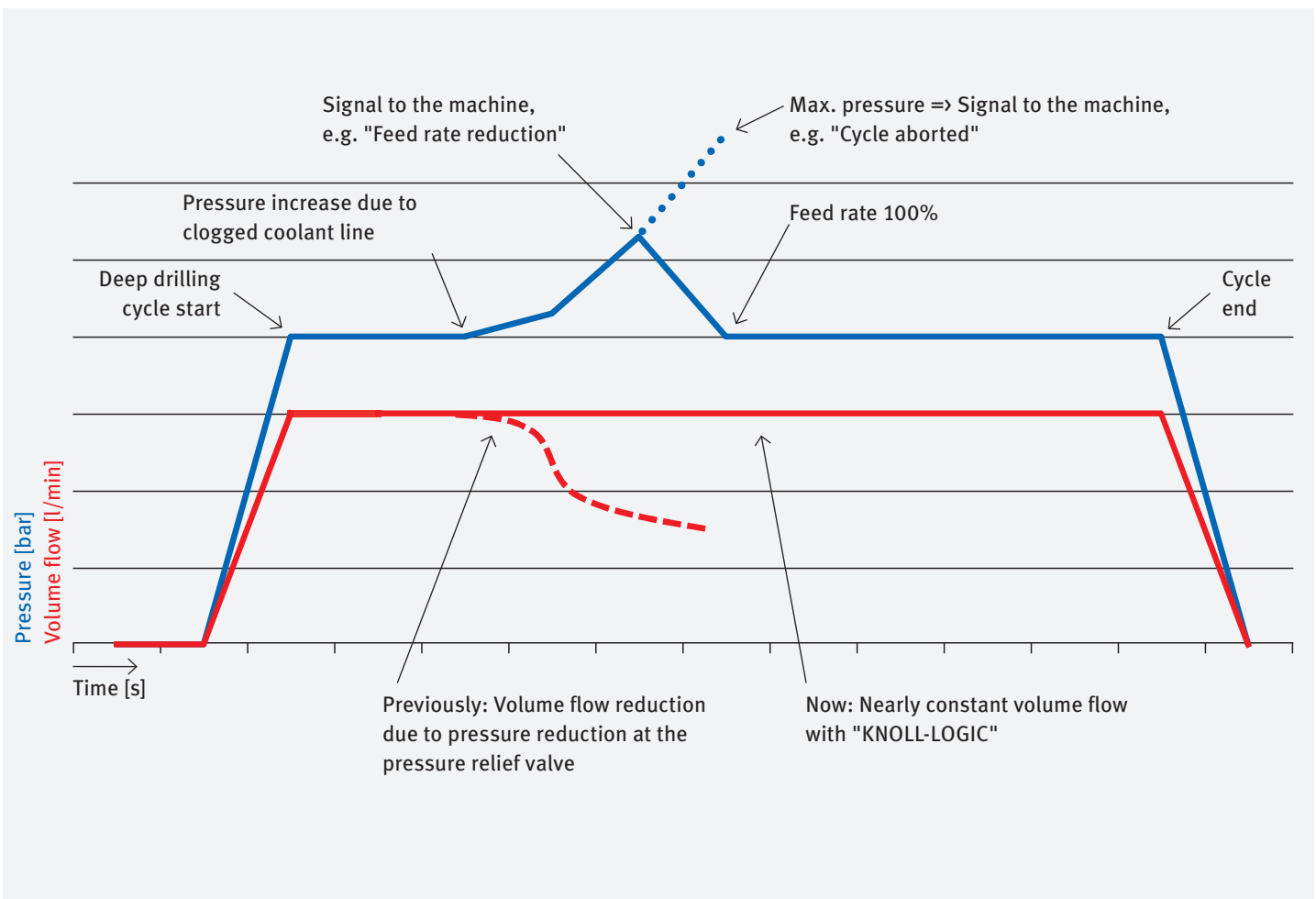

Pressure intensifier with screw pump with dry installation and frequency control

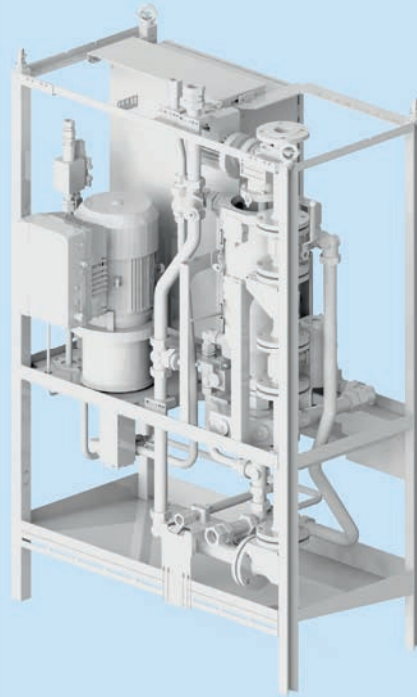

Screw pump with dry installation and frequency control

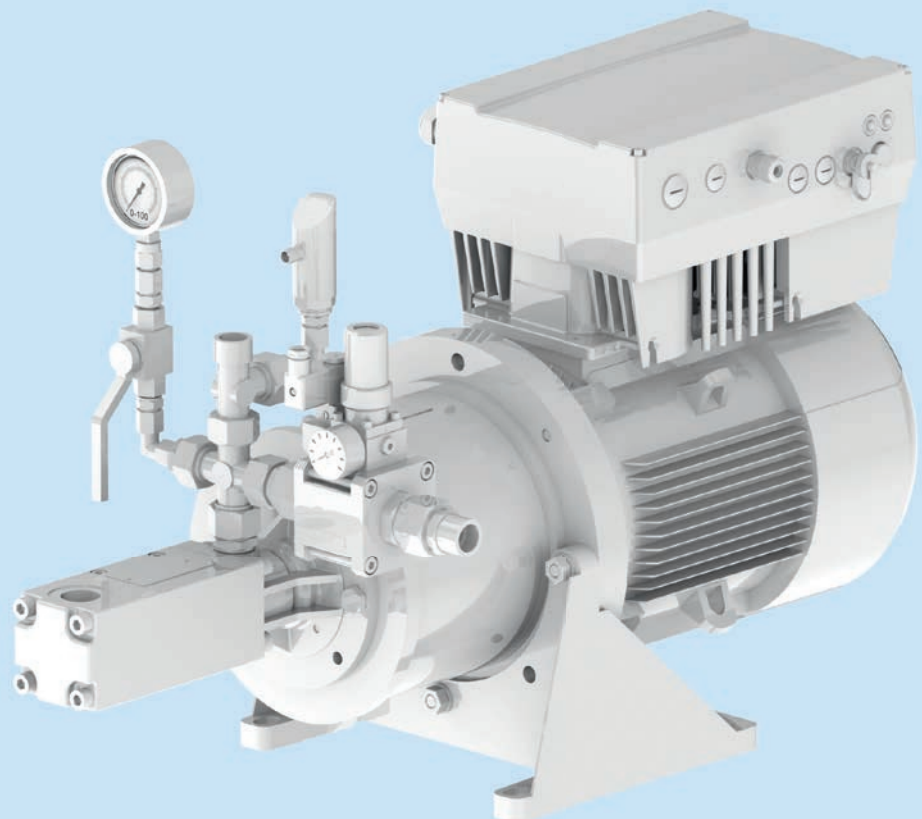

Screw pump

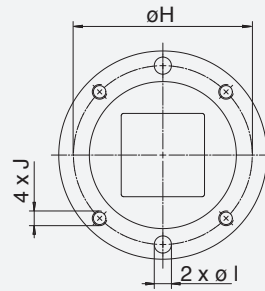
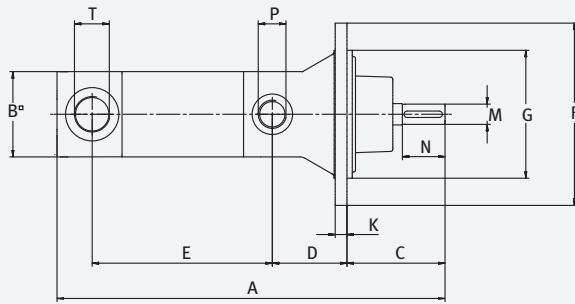

KTS 20/25

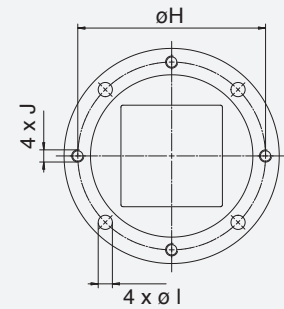

KTS 32/40/50/60

Weight and dimension information subject to correction
Dimensions only applicable for pumps with T design

KTS pump size	Main dimensions [mm]											Pressure connection	Suction connection	Shaft end [mm]		Weight [kg]
	A	B	C	D	E	F	G	H	I	J	K			P	T	
20 ...	341	80	92	70	144	171	120	146	14	M 12	11	G 1/2	G 1	19	40	12
25 ...	366	80	92	70	169	171	120	146	14	M 12	11	G 3/4	G 1	19	40	13
32 ...	440	100	100	82	213	212	155	185	14	M 12	14	G 1	G 1 1/2	24	40	24
40 ...	508	120	105	84	272	212	155	185	14	M 12	15	G 1 1/2	G 2	28	45	36
50 ...	599	140	119	97	329	240	170	205	18	M 16	17	G 1 1/2	G 2	32	55	57
60 ...	751	176	143	102	408	350	250	300	22	M 20	19	SAE 2	SAE 3	48	65	121

Pump plate/screw pump attachment

KTS 20/25

KTS 32/40

KTS 50

KTS 60

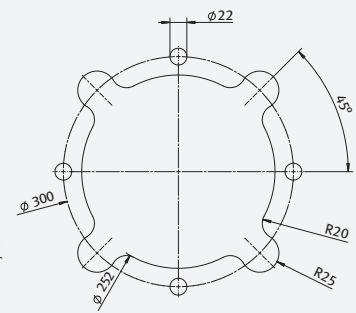
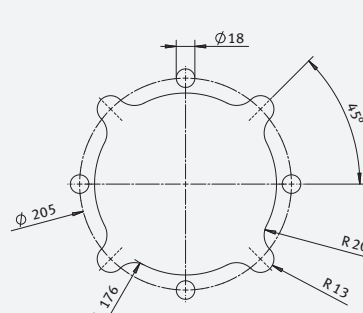
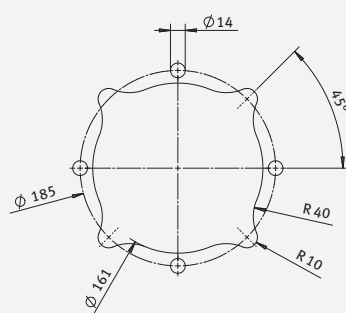
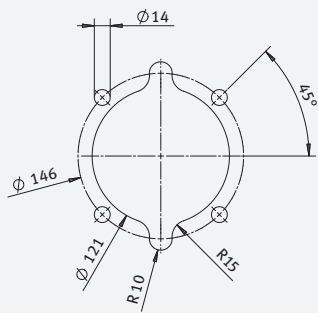

General tolerances in accordance with ISO 2768-m. Sheet thicknesses differ depending on pump size.

-T version

-T-A-G-KB-B version

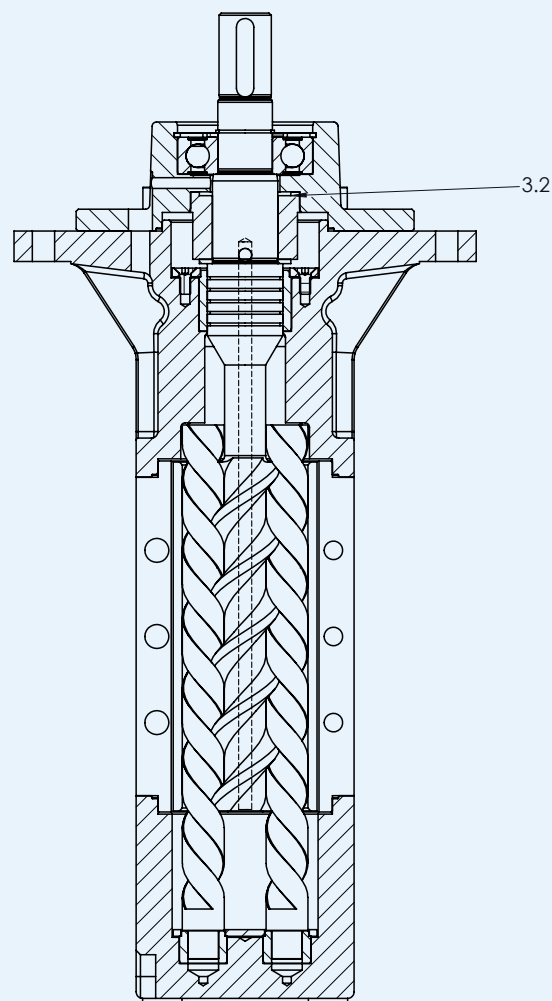
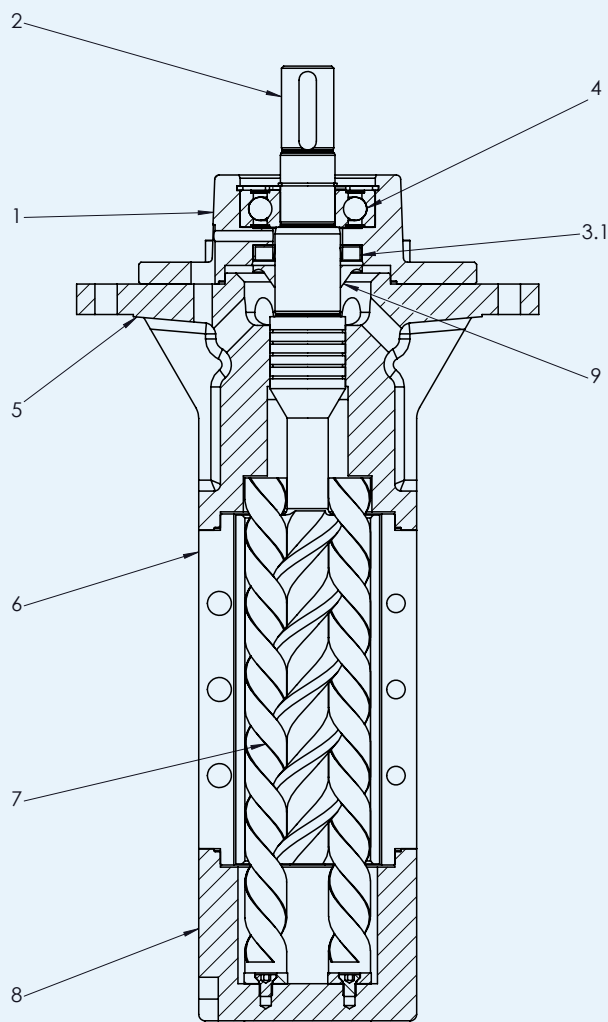

Position	Designation	Position	Designation
1	Bearing cover	6	Running casing
2	Drive spindle	7	Running spindle
3.1	Rotary shaft seal (for -T version only)	8	Suction housing
3.2	Axial face seal (for -T-G version only)	9	Skid ring
4	Deep groove ball bearing		
5	Pressure casing		

Pumps with submersion design

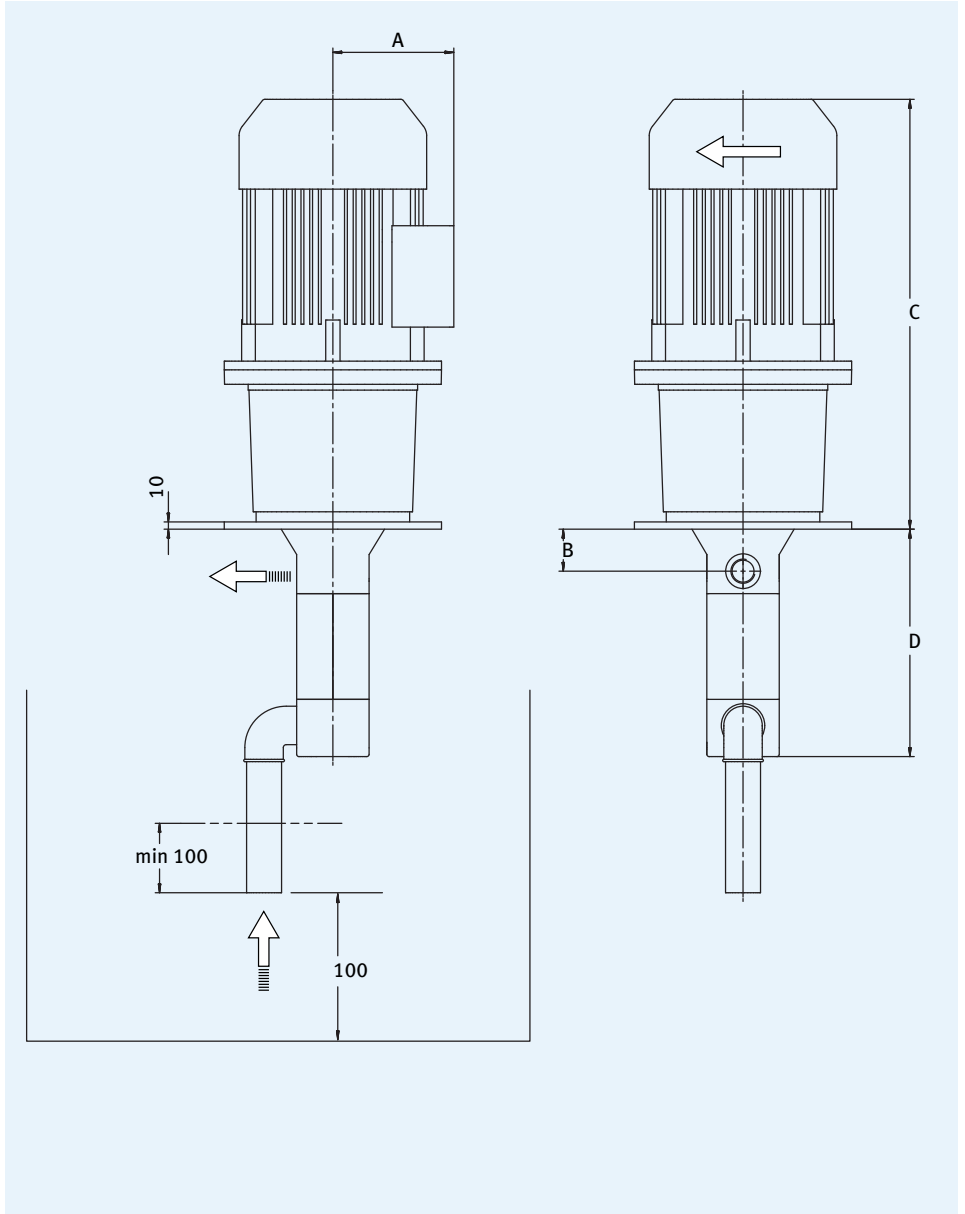

Pumps with submersion design

KTS pump	Motor size	Main dimensions [mm]				Weight [kg]	
		A	B	C (IE3)	D*	2-pole IE3	4-pole IE3
	80M	149		421		25	28
	80M	149		456		26	-
	90S	155		466		29	30
	90L	155		496		33	33
20	100L	170		567		39	43
	100L	170	49	567	242	-	43
	112M	176		550		47	47
	132S	201		602		57	78
	132S	201		652		71	-
	132M	201		652		-	78
	160M	235		743		90	98
	90S	155		466		30	31
	90L	155		466		34	34
	100L	170		567		41	45
25	100L	170		567		-	45
	112M	176	49	550	267	49	49
	132S	201		602		58	79
	132S	201		652		72	-
	132M	201		652		-	79
	160M	235		743		92	100
	160M	235		743		101	-
	90S	155		496		41	42
	90L	155		526		45	45
	100L	170		570		52	56
32	100L	170		570		-	56
	112M	176		553		60	60
	132S	201		605		69	90
	132S	201	58	655	330	83	-
	132M	201		655		-	90
	160M	235		774		103	111
	160M	235		774		112	-
	160L	235		834		122	128
	180M	286		868		188	193
	200L	315		891		280	-
40	200L	315		916		255	270
	112M	176		554		72	72
	132S	201		606		81	102
	132S	201		656		95	-
	132M	201		656		-	102
	160M	235		775		115	123
	160M	235	59	775	387	124	-
	160L	235		835		134	140
	180M	286		869		200	205
	180L	286		869		-	210
50	200L	315		892		267	282
	200L	315		917		292	-
	132S	201		668		102	123
	132S	201		718		116	-
	132M	201		718		-	123
	160M	235		777		136	144
	160M	235		777		145	-
	160L	235		837		155	161
	180M	286	70	871	474	221	226
	180L	286		871		-	231
60	200L	315		894		288	303
	200L	315		919		313	-
	225S	345		960		-	349
	225M	345		1020		379	-
	225M	345		1020		-	384
	160M	235		779		200	208
	160M	235		779		209	-
	160L	235		839		219	225
	180M	286		873		285	290
	180L	286		873		-	295
60	200L	315		896		352	367
	200L	315		921		377	-
	225S	345		962		-	413
	225M	345	73	999	579	442	-
	225M	345		999		-	448
	250M	417		1091		520	-
	250M	417		1091		-	555
	280S	433		1164		645	-
	280S	433		1164		-	706
	280M	433		1274		725	-
280M	433		1274		-	806	

Weight and dimensional details subject to correction / * Dimensions only applicable for T pumps

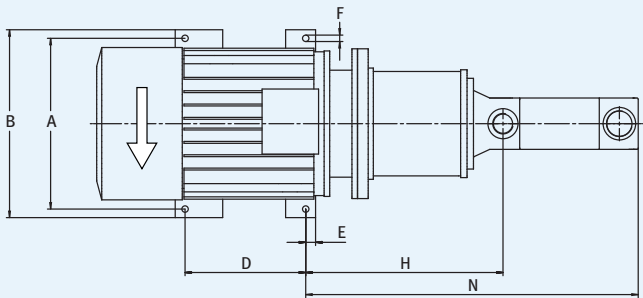
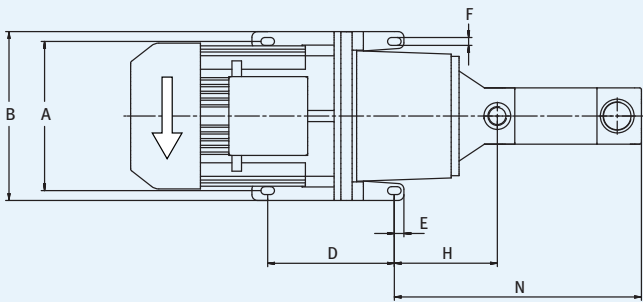
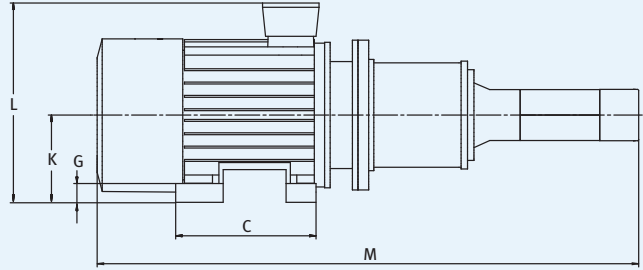
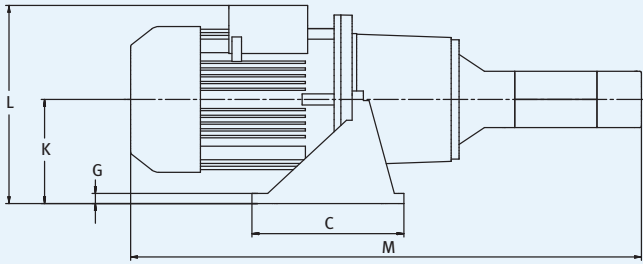
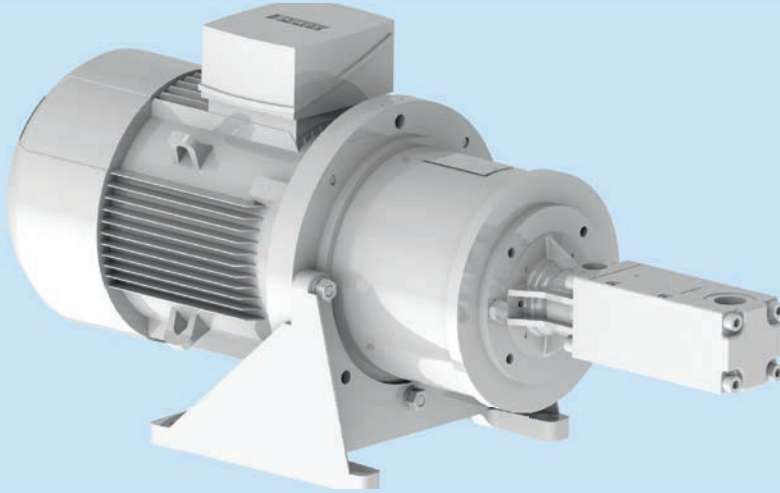

Applicable for motors with sizes of 80M to 225M, structural shape B5 or V1

Applicable for motors with sizes of 250M to 315M, structural shape B35

Pump KTS	Motor size		Main dimensions [mm]										Weight [kg]			
	A	B	C	D	E	F	G	H	K	L	M*	N*	2-pole IE3	4-pole IE3		
20	80M	180	210	90	60	15	11	12	138	112	261	663	320	25	28	
	80M	180	210	90	60	15	11	12	138	112	261	698	320	26	-	
	90S	180	210	90	60	15	11	12	138	112	267	708	320	29	30	
	90L	180	210	90	60	15	11	12	138	112	267	738	320	33	33	
	100L	215	250	230	185	22.5	14	16	167	155	325	809	349	41	45	
	100L	215	250	230	185	22.5	14	16	167	155	325	809	349	-	45	
	112M	215	250	230	185	22.5	14	16	167	155	331	792	349	49	49	
	132S	265	300	270	225	22.5	14	19	171	185	386	844	353	60	81	
	132S	265	300	270	225	22.5	14	19	171	185	386	894	353	74	-	
	132M	265	350	305	265	20	18	19	183	235	436	894	365	-	81	
	160M	300	350	305	265	20	18	19	183	235	470	985	365	95	103	
	90S	180	210	90	60	15	11	12	138	112	267	708	345	31	32	
90L	180	210	90	60	15	11	12	138	112	267	733	345	35	35		
100L	215	250	230	185	22.5	14	16	167	155	325	834	374	43	47		
100L	215	250	230	185	22.5	14	16	167	155	325	834	374	-	47		
25	112M	215	250	230	185	22.5	14	16	167	155	331	817	374	51	51	
	132S	265	300	270	225	22.5	14	19	171	185	386	869	378	61	82	
	132S	265	300	270	225	22.5	14	19	171	185	386	919	378	75	-	
	132M	265	350	305	225	22.5	18	19	171	185	386	919	378	-	82	
	160M	300	350	305	265	20	18	18	183	235	470	1010	390	97	105	
	160M	300	350	305	265	20	18	18	183	235	470	1010	390	106	-	
	90S	180	250	90	60	15	14	12	138	155	310	826	399	42	43	
	90L	180	250	230	185	22.5	14	15	179	155	310	856	440	46	46	
	100L	215	250	230	185	22.5	14	16	179	155	325	900	440	54	58	
	100L	215	250	230	185	22.5	14	16	179	155	325	900	440	-	58	
	112M	215	250	230	185	22.5	14	16	179	155	331	883	440	62	62	
	132S	265	300	270	225	22.5	14	19	183	185	386	935	444	72	93	
32	132S	265	300	270	225	22.5	14	19	183	185	386	985	444	86	-	
	132M	265	350	305	225	22.5	18	19	183	185	386	985	444	-	93	
	160M	300	350	305	265	20	18	18	223	235	470	1104	484	108	116	
	160M	300	350	305	265	20	18	18	223	235	470	1104	484	117	-	
	160L	300	350	305	265	20	18	18	223	235	470	1164	484	127	133	
	180M	300	350	305	265	20	18	18	223	235	521	1198	484	193	198	
	200L	350	400	355	305	25	25	20	219	200	515	1221	480	283	-	
	200L	350	400	355	305	25	25	20	219	200	515	1246	480	258	273	
	112M	215	250	230	185	22.5	14	16	181	155	331	931	499	74	74	
	132S	265	300	270	225	22.5	14	19	185	185	386	983	503	84	-	
	132S	265	300	270	225	22.5	14	19	185	185	386	1033	503	98	41	
	132M	265	350	305	225	22.5	18	19	185	185	386	1033	503	-	105	
40	160M	197	350	305	265	20	18	18	225	235	470	1152	543	120	128	
	160M	300	350	305	265	20	18	18	225	235	470	1152	543	129	-	
	160L	300	350	305	265	20	18	18	225	235	470	1212	543	139	145	
	180M	300	350	305	265	20	18	18	225	235	521	1246	543	205	210	
	180L	300	350	305	265	20	18	18	225	235	521	1246	543	-	213	
	200L	350	400	355	305	25	25	20	221	200	515	1269	539	270	285	
	200L	350	400	355	305	25	25	20	221	200	515	1294	539	295	-	
	132S	265	300	270	225	22.5	14	19	185	185	386	1142	568	105	126	
	132S	265	300	270	225	22.5	14	19	185	185	386	1192	568	119	-	
	132M	265	350	305	225	22.5	18	19	185	185	386	1192	568	-	126	
	160M	300	350	305	265	20	18	18	238	235	470	1251	621	141	149	
	160M	300	350	305	265	20	18	18	238	235	470	1251	621	150	-	
50	160L	300	350	305	265	20	18	18	238	235	470	1311	621	160	166	
	180M	300	350	305	265	20	18	18	238	235	521	1345	621	226	231	
	180L	300	350	305	265	20	18	18	238	235	521	1345	621	-	234	
	200L	350	400	355	305	25	25	20	234	200	515	1368	617	291	306	
	200L	350	400	355	305	25	25	20	234	200	515	1393	617	316	-	
	225S	400	450	385	347	34	18	22	253	295	633	1412	636	-	349	
	225M	400	450	385	347	34	18	22	253	295	633	1472	636	379	-	
	225M	400	450	385	347	34	18	22	253	295	633	1472	636	-	384	
	160M	300	350	305	265	20	18	18	166	235	470	1358	672	205	213	
	160M	300	350	305	265	20	18	18	166	235	470	1358	672	214	-	
	160L	300	350	305	265	20	18	18	166	235	470	1418	672	224	230	
	180M	300	350	305	265	20	18	18	166	235	521	1452	672	290	295	
180L	300	350	305	265	20	18	18	166	235	521	1452	672	-	300		
60	200L	350	400	355	305	25	25	20	508	200	515	1475	1014	355	370	
	200L	350	400	355	305	25	25	20	508	200	515	1500	1014	380	-	
	225S	400	450	385	347	34	18	22	259	295	633	1603	765	-	413	
	225M	400	450	385	347	34	18	22	259	295	633	1603	765	442	-	
	225M	400	450	385	347	34	18	22	259	295	633	1603	765	-	448	
	250M	406	490	409	349	30	30	40	585	250	667	1670	1091	520	-	
	250M	406	490	409	349	30	30	40	585	250	667	1670	1091	-	555	
	280S	457	540	479	368	30	30	40	607	280	713	1743	1113	645	-	
	280S	457	540	479	368	30	30	40	607	280	713	1743	1113	-	706	
	280M	457	540	479	419	30	30	40	607	280	713	1853	1113	725	-	
	280M	457	540	479	419	30	30	40	607	280	713	1853	1113	-	806	

Weight and dimensional details subject to correction / * Dimensions only applicable for T pumps

Frequency inverter (FI) 0.75 – 22.0 kW

Benefits

- Compact design thanks to installation of the FI on the terminal box of the motor (piggyback).
- Control system incorporates KNOLL control expertise.

Recommended motor output [kW]	0.75	1.10	1.50	2.20	3.00	4.00	5.50	7.50	11.00	15.00	18.50	22.00
Mains current [A]	1.90	2.60	3.30	4.60	6.20	7.90	10.80	14.80	23.20	28.20	33.20	39.80
Rated output current [A] with 400 V/8 kHz	2.30	3.10	4.00	5.60	7.50	9.50	13.00	17.80	28.00	34.00	40.00	48.00
Size	A			B			C	D				
Weight incl. worktop [kg]	3.9			5.0			8.7	21.0				
Protection rating	IP 65							IP 55				
Max. overload for 60 sec [%]	150											130
Mains voltage	3 AC 400 V -15% to 480 V +10%											
Mains frequency	50/60 Hz ±6%											
EMC approval	Complies with DIN EN 61800-3, Class C2											
Certificate and conformity	CE and UL											
Temperature range	-25 °C (without condensation) to +50 °C (without derating)											
Protective functions	Over/undervoltage, I ² t limiting, short circuit, motor temperature, inverter temperature, tilt protection, locked rotor protection											
Output frequency range	0 – 400 Hz											
Digital inputs	4											
Fixed frequency	7											
Digital outputs	2											
Analog inputs	2 analogue inputs (0/2 - 10 V, 0/4 - 20 mA)											
Analog outputs	0 - 10 V (-I _{max} = 10 mA) or 0 - 20 mA (-load R = 500 Ω)											
Process control	Freely configurable PID controller											
Relay outputs	2 make contacts, 250 V AC 2 A											
USB interface	USB on M12 connector (RS485/RS232 converter)											
Handheld terminal (optional)	MMI with lead											
Bus modules (optional)	Profinet, Profibus DP, CANopen, EtherCAT											
Other versions	Secure grip											

Dimensions

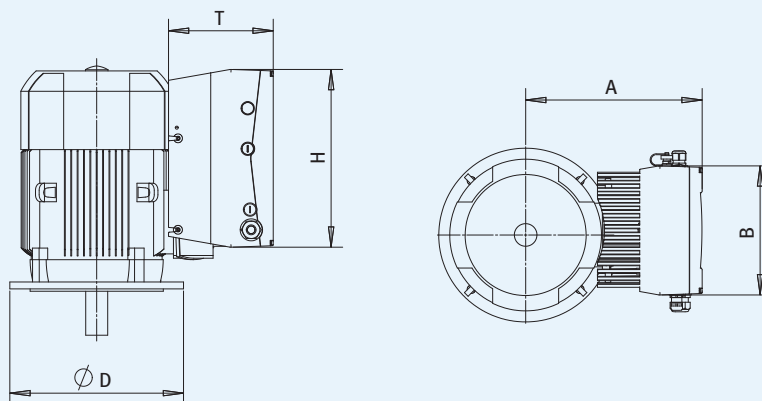

Motor output [kW]	Size	Main dimensions [mm]				
		A	B	D	H	T
0.75 - 1.5	A	205	153	200	233	120
2.2	B	230	189	200	270	140
3.0	B	235	189	250	270	140
4.0	B	245	189	250	270	140
5.5 - 7.5	C	310	223	300	307	181
11.0 - 18.5	D	410	294	350	414	232
22.0	D	450	294	350	414	232

Three-phase motor, 2-pole/4-pole,
thermal class ISO-F, protection rating IP 55, IE3

0.75 kW to 5.5 kW 7.5 kW to 90 kW
230 VΔ/400 VY 50 Hz 400 VΔ/690 VY 50 Hz
460 VY 60 Hz 460 VΔ 60 Hz
Other voltages available on request.

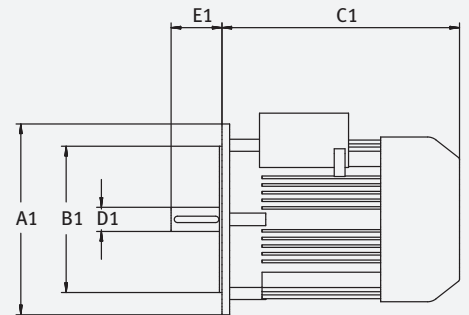

Technical data of the standard-dimensioned motors IEC/EN 60034

Switch-on frequency: In order to keep the load on the pump and motor as low as possible, the switch-on frequency for a switch-on operation per minute should not be exceeded. For short switching operations, the pumps should cycle and enable the medium to flow away without pressure via suitable valves (see Pages 36-37).

50 Hz 2-pole = 2900 rpm			50 Hz 4-pole = 1450 rpm			60 Hz 2-pole = 3500 rpm			60 Hz 4-pole = 1750 min			Size Sound pressure level	Main dimensions [mm]					Weight [kg]	
Power	Nominal current	Sound pressure level	Power	Nominal current	Sound pressure level	Power	Nominal current	Sound pressure level	Power	Nominal current	Sound pressure level		A1	B1	C1 (IE3)	D1	E1	2-pole	4-pole
[kW]	IE3 [A]	[dB(A)]	[kW]	IE3 [A]	[dB(A)]	[kW]	NPE [A]	[dB(A)]	[kW]	NPE [A]	[dB(A)]						IE3	IE3	
0.75	1.56	60	0.75	1.75	53	0.75	1.46	64	0.75	1.53	55	80M	200	130	252	19	40	11	14
1.1	2.25	60	-	-	-	1.1	1.98	64	-	-	-	80M	200	130	287	19	40	12	-
1.5	3	65	1.1	2.4	53	1.5	2.6	69	1.1	2.1	55	90S	200	130	297	24	50	15	16
2.2	4.2	65	1.5	3.15	53	2.2	3.65	69	1.5	2.85	55	90L	200	130	327	24	50	19	19
3	5.6	67	2.2	4.4	53	3	4.9	71	2.2	3.8	55	100L	250	180	371	28	60	26	30
-	-	-	3	5.9	53	-	-	-	3	5.1	55	100L	250	180	371	28	60	-	30
4	7.4	69	4	7.9	58	3.7	6	73	3.7	6.5	62	112M	250	180	354	28	60	34	34
5.5	9.9	68	5.5	10.5	58	5.5	8.6	72	5.5	9.1	62	132S	300	230	385	38	80	43	64
7.5	13.1	68	-	-	-	7.5	11.5	72	-	-	-	132S	300	230	435	38	80	57	-
-	-	-	7.5	14.3	58	-	-	-	7.5	12.4	62	132M	300	230	435	38	80	-	64
11	20	70	11	20.5	58	11	17.2	77	11	18	62	160M	350	250	494	42	110	75	83
15	27	70	-	-	-	15	24	77	-	-	-	160M	350	250	494	42	110	84	-
18.5	32	70	15	28.5	65	18.5	28	77	15	25	69	160L	350	250	554	42	110	94	100
22	38.5	73	18.5	35	66	22	34.5	77	18.5	31	68	180M	350	250	588	48	110	160	165
-	-	-	22	41.5	68	-	-	-	22	37	70	180L	350	250	588	48	110	-	170
30	53	73	30	55	65	30	46.5	78	30	48	67	200L	400	300	611	55	110	225	240
37	65	74	-	-	-	37	57	79	-	-	-	200L	400	300	636	55	110	250	-
-	-	-	37	66	66	-	-	-	37	58	69	225S	450	350	648	60	140	-	285
45	78	76	-	-	-	45	68	77	-	-	-	225M	450	350	708	55	110	315	-
-	-	-	45	80	66	-	-	-	45	70	69	225M	450	350	708	55	110	-	320
55	95	76	-	-	-	55	84	80	-	-	-	250M	550	450	747	60	140	385	-
-	-	-	55	96	66	-	-	-	55	86	69	250M	550	450	747	65	140	-	420
75	128	76	-	-	-	75	112	81	-	-	-	280S	550	450	820	65	140	510	-
-	-	-	75	133	71	-	-	-	75	115	79	280S	550	450	820	65	140	-	570
90	152	76	-	-	-	90	137	81	-	-	-	280M	550	450	930	65	140	590	-
-	-	-	90	157	71	-	-	-	90	141	79	280M	550	450	930	65	140	-	670

Pressure limiting valves

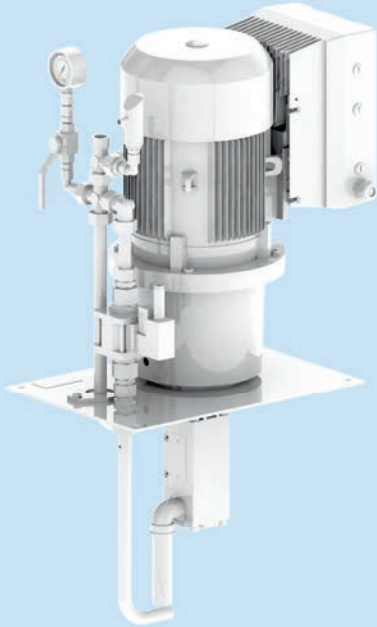

Screw pumps are displacement pumps that must be pressure-limited depending on the system in order to keep the nominal current of the motor within limits. Pressure relief valves, which ensure the set pressure alongside the burst protection, are suitable for this purpose. The use of damped valves on the screw pumps can prevent pressure shocks. In the event of overpressure, the excess amount flows out via the valve.

Selection criteria

Valves are selected based on the factors of pressure, flow rate, viscosity and adjustability.

Benefits

- Robust, resistant to contamination
- Control element separated from the cooling lubricant
- Simple pressure changes
- No pressure shocks in the pipework
- Constant pressure within a wide range
- Cyclical circuit with minimal pressure possible



Uncontrolled pressure relief valve PRV (adjustable with tool)

Function

The activation pressure of the valve is adjusted via an adjusting screw. When the activation pressure is reached, the valve plug opens and the operating medium flows out from the pressure connection via the tank connection. The valve should preferably be installed vertically with the adjusting screw facing downwards. The maximum flow rate is achieved without a significant increase in pressure.

Type	Pressure [bar]	Flow rate Q_{max} [l/min]	Connection thread
DBD040	10 - 30	60	G 3/4
DBD085	20 - 60	60	G 3/4
DBD130	50 - 110	60	G 3/4
DBD150	100 - 150	105	G 3/4

Pneumatically controlled pressure relief valve HPB (manually adjustable)

Function

The operating pressure of the valve can be adjusted via a handwheel. Cyclical circuit with minimal pressure can be actuated electrically. When de-energised and not pressurised, the valve is open.

Type	Pressure [bar]	Flow rate Q_{max} [l/min]	Connection thread
3-HPB-H-12/200	10 - 200	85	G 1
3-HPB-H-15	5 - 120	100	G 1
3-HPB-S-15	5 - 63	100	G 1
3-HPB-H-32	5 - 120	240	G 1 1/2
3-HPB-S-32	5 - 63	400	G 1 1/2
3-HPB-S-50	5 - 63	800	G 1 1/2

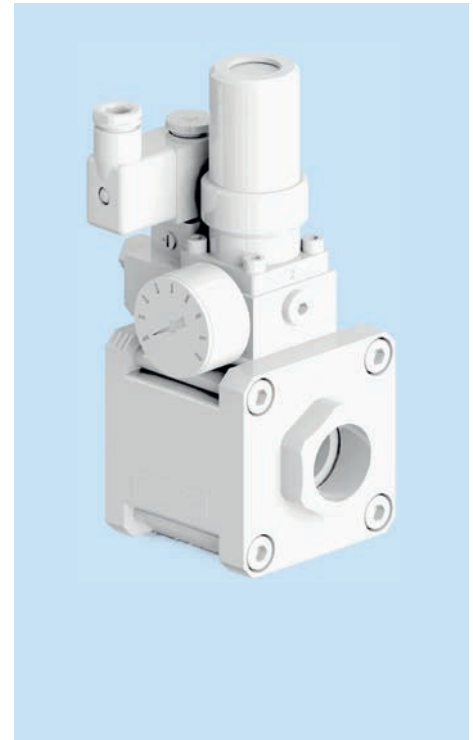

Pneumatically controlled pressure relief valve SPB (controlled electronically)

Function

The vario valve enables users to specify any pressure level within the 5 to 160 bar range. The machine control system converts digital signals into analogue valves for pressure control purposes (0 – 10 V). The pneumatic control pressure changes proportionally to the analogue valve and controls the medium pressure. When de-energised and not pressurised, the valve is open.

Type	Pressure [bar]	Flow rate Q_{max} [l/min]	Connection thread
SPB-H-12/200	10 - 200	85	G 1
SPB-H-15	5 - 120	100	G 1
SPB-S-15	5 - 63	100	G 1
SPB-H-32	5 - 120	240	G 1 1/2
SPB-S-32	5 - 63	400	G 1 1/2
SPB-S-50	5 - 63	800	G 1 1/2



The air connection must be kept at a constant value with a pressure regulator.
For minimum control pressure, see Page 38-39.
Valves for higher flow rates and pressures available on request.

Characteristic curves for controlled pressure relief valves

3-HPB-H-12/200 | SPB-H-12/200

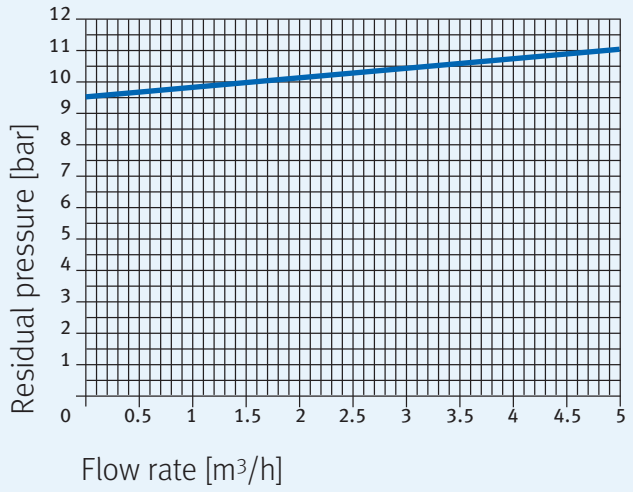
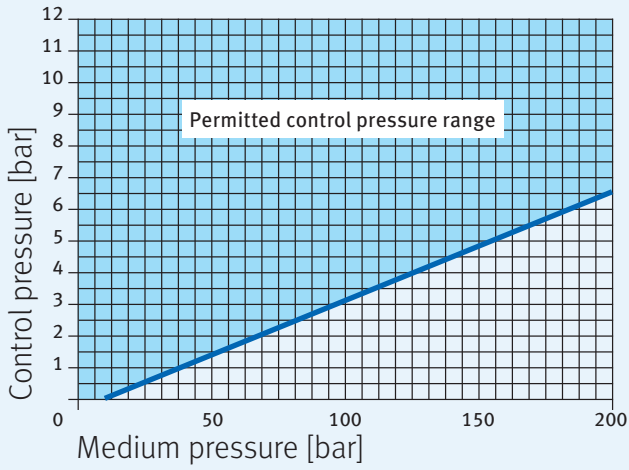

3-HPB-S-15 | SPB-S-15

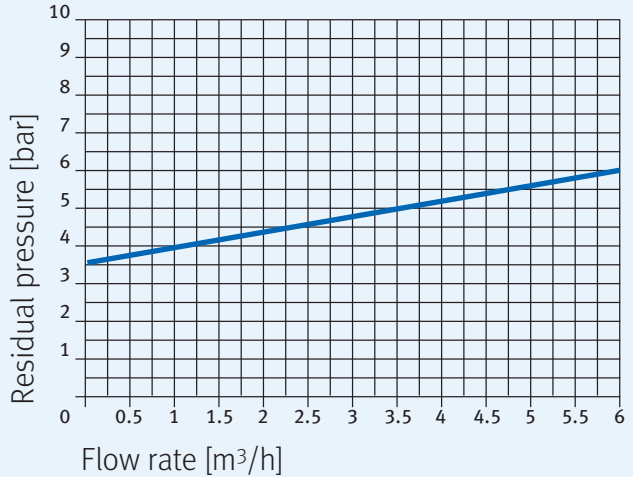
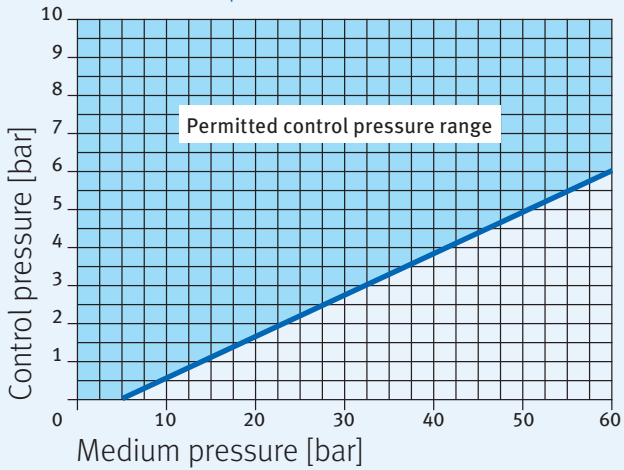

3-HPB-H-15 | SPB-H-15

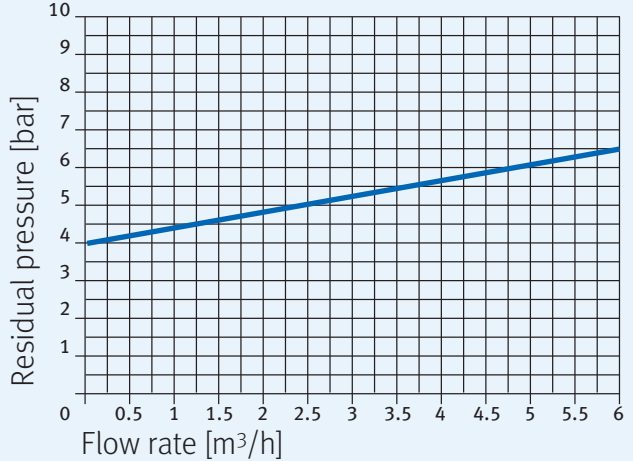
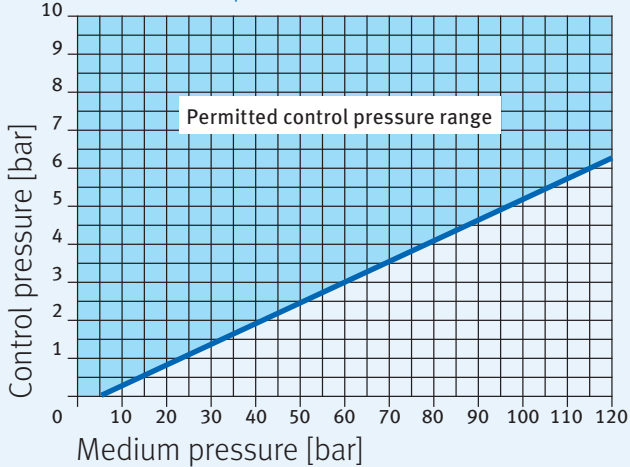

To enable full utilisation of the pressure range, the corresponding control pressure must be available.

3-HPB-S-32 | SPB-S-32

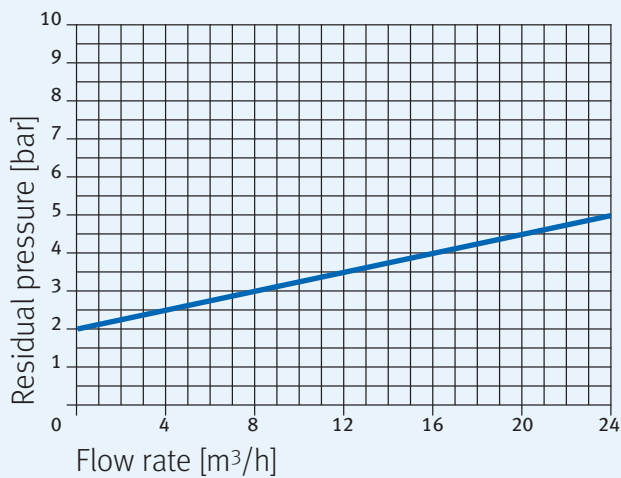
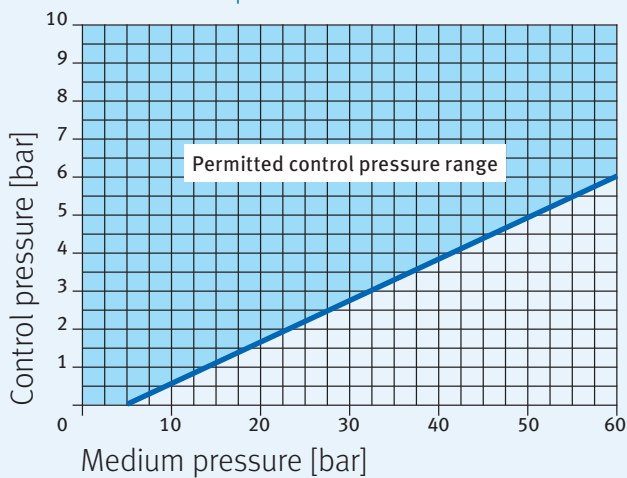

3-HPB-H-32 | SPB-H-32

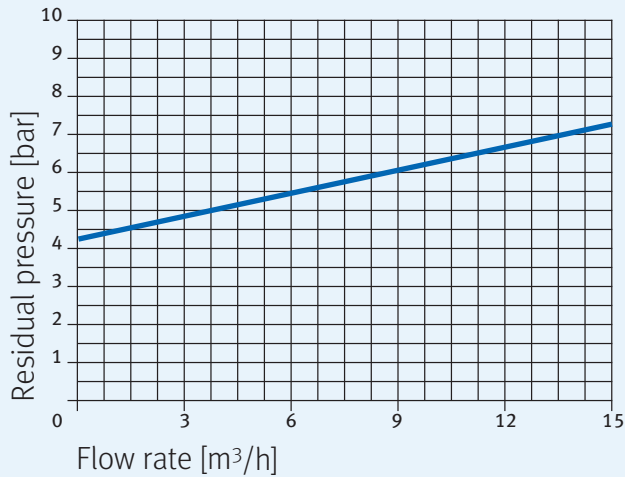
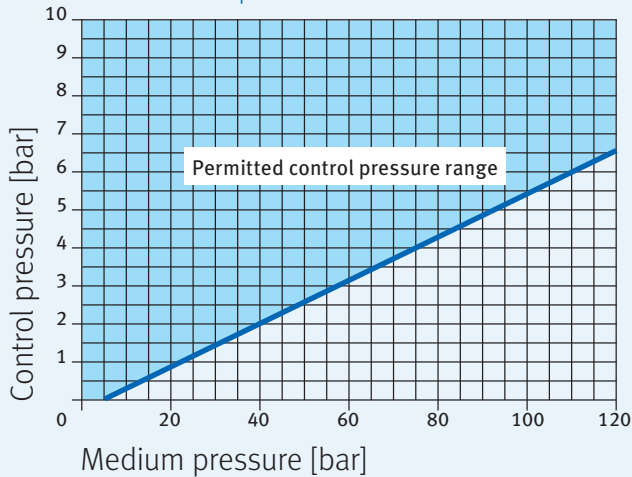

3-HPB-S-50 | SPB-S-50

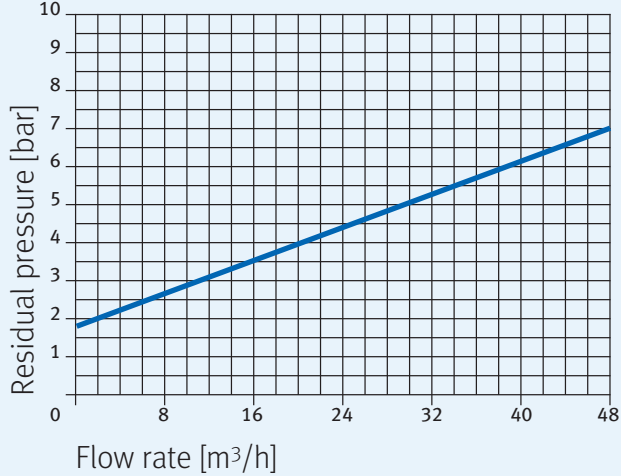
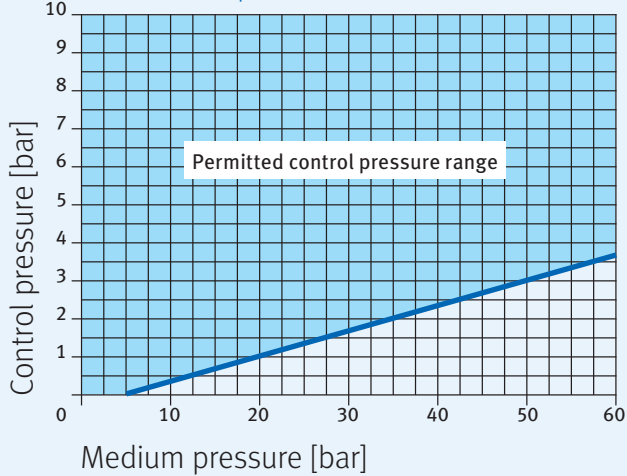

To enable full utilisation of the pressure range, the corresponding control pressure must be available.

KNOLL Maschinenbau GmbH
Schwarzachstraße 20
D-88348 Bad Saulgau
Tel. +49 7581 2008-0
Fax +49 7581 2008-90140
info.itworks@knoll-mb.de
www.knoll-mb.com

KTS